



INTERNATIONAL APPLICATION PUBLISHED UNDER THE PATENT COOPERATION TREATY (PCT)

<p>(51) International Patent Classification ⁵ : E04B 1/10</p>	<p>A1</p>	<p>(11) International Publication Number: WO 92/17657 (43) International Publication Date: 15 October 1992 (15.10.92)</p>
<p>(21) International Application Number: PCT/US92/01748 (22) International Filing Date: 6 March 1992 (06.03.92) (30) Priority data: 678,221 1 April 1991 (01.04.91) US (71)(72) Applicant and Inventor: LINDAL, Walter [US/US]; 1120 8th Avenue N., Suite 2201, Seattle, WA 98101 (US). (81) Designated States: AT (European patent), AU, BE (European patent), CA, CH (European patent), DE (European patent), DK (European patent), ES (European patent), FR (European patent), GB, GB (European patent), GR (European patent), IT (European patent), JP, KR, LU (European patent), MC (European patent), NL (European patent), NO, SE, SE (European patent).</p>		<p>Published <i>With international search report. Before the expiration of the time limit for amending the claims and to be republished in the event of the receipt of amendments.</i></p>

(54) Title: WOODEN FRAME BUILDING CONSTRUCTION

(57) Abstract

What is disclosed is a wide variety of roofing planks, siding planks and floor planks (7) connected to rafters, studs and joists (9) without visible nails (13). Planks may be covered with sheet metal (4), which is not pierced by nailing. The building system is improved further by taking advantage of the tendency for resawn (5) planks to cup.

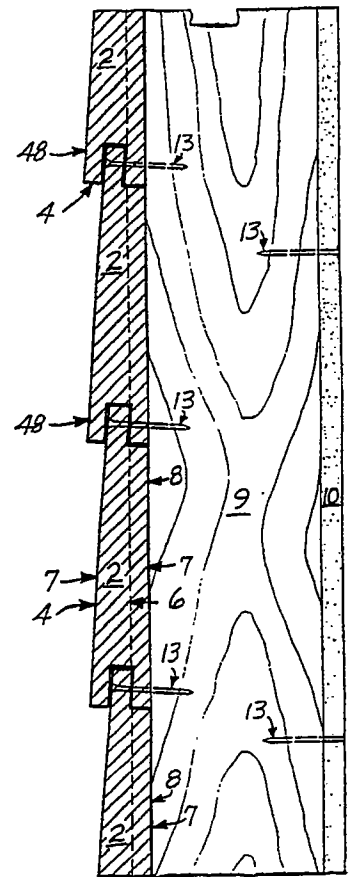

FOR THE PURPOSES OF INFORMATION ONLY

Codes used to identify States party to the PCT on the front pages of pamphlets publishing international applications under the PCT.

AT	Austria	FI	Finland	ML	Mali
AU	Australia	FR	France	MN	Mongolia
BB	Barbados	GA	Gabon	MR	Mauritania
BE	Belgium	GB	United Kingdom	MW	Malawi
BF	Burkina Faso	GN	Guinea	NI	Netherlands
BG	Bulgaria	GR	Greece	NO	Norway
BJ	Benin	HU	Hungary	PL	Poland
BR	Brazil	IE	Ireland	RO	Romania
CA	Canada	IT	Italy	RU	Russian Federation
CF	Central African Republic	JP	Japan	SD	Sudan
CG	Congo	KP	Democratic People's Republic of Korea	SE	Sweden
CH	Switzerland	KR	Republic of Korea	SN	Senegal
CI	Côte d'Ivoire	LI	Liechtenstein	SU	Soviet Union
CM	Cameroon	LK	Sri Lanka	TD	Chad
CS	Czechoslovakia	LU	Luxembourg	TG	Togo
DE	Germany	MC	Monaco	US	United States of America
DK	Denmark	MG	Madagascar		
ES	Spain				

DescriptionWOODEN FRAME BUILDING CONSTRUCTIONTechnical Field

This invention is an extension of the art taught in my U.S. Patent Number 4,065,902, granted to me January 3, 1978, and relates to further improvements in the same field and is extended to wood siding and flooring, including modifications to both the covering materials and the wood framing members to which they are attached. The problem with my prior invention is that the metal covered wood roofing planks had to be narrow in order that a single nail at one edge could properly fasten the planks to the roof framing. Wide roofing planks could not be adequately nailed and worst of all, such single edge nailing did not provide adequate resistance to shear forces, even when using narrow planks with more nailing.

Also in building construction, other similar problems are apparent that could be solved by an improved method of attaching siding, floor boards and roof boards in a manner where they are adequately attached, resist shear and have no face nailing. There is no use having water proof joints between metal covered roof planks if you are going to pierce the face of the metal by nailing. The same goes, to a lesser extent, to metal covered wood siding. However, metal covered siding, and even wood siding that is not metal covered, such as log siding, can have their appearance ruined by tradesmen who leave hammer marks when they nail. In the case of log siding, which is intended to appear as if the wall is solid logs, vertical rows of hammer marks and nail heads showing every two feet along the wall make it apparent, even to the novice, that it is only wood siding. Face nailing of wood outside decks spoils the deck's appearance and people often trip on spike heads that have worked up. When one observes old houses, it can be noted that hammer marks start face decay

and that sweating of nail heads, and the nails themselves, cause rot around the nails to such an extent that sometimes the siding can be pulled off right over the nail heads and often the heads have been rusted off. Even if the nails are sheltered from the weather they cause deterioration in time. They pierce a hole through the siding, and water vapor from inside the house finds escape along the nail causing it to rust and the wood to deteriorate. My invention teaches how to fasten the roof boards, the siding, the decking and the flooring to their respective rafters, studs and joists without face nailing. My answer is a means to lock the cladding to the rafters, studs or joists with a special dovetail joint. This system eliminates the need for plywood sheathing or braces to resist shear by locking the elements together, like an egg crate, which provides even greater shear resistance when wider planks are used. Both the cladding and the framing members have to be modified to obtain the locked on feature. The cross groove on the cladding has to be undercut on its sides to form a locking dovetail means. The framing rafters, studs or joists have a similar dovetailed male end that is slit on its end to allow the sides of the male edge to be squeezed together to fit between the outer lips of the cross groove as the cladding is forced on it. The sides will snap back to their original configuration when the male edge of the framing is all the way in, locking the cladding permanently to the framing.

If the roofing planks, or the siding planks, are metal covered, the metal can be formed, as taught in my 1978 invention, to make their edge joints waterproof. Nails can be used, as taught in this invention, if they are hidden in the tongue and grooves. In the woodworking art, tradesmen have always been frustrated by the fact that

when a plank is resawn into two boards, the boards will tend to cup on the resawn side. This happens because, no matter how dry we kiln dry the plank on its outside, the heart of the plank will always be wetter. When the plank is split into two boards, the wetter inside face will slowly air dry until it is the same moisture content as the outside. This causes the inside to shrink as it dries, cupping the board in accordance to the difference in dryness. This invention takes advantage of this, otherwise, unfortunate phenomena. Bevelled boards make the best siding, or roof boards. These are always made by diagonally sawing square planks into two bevelled boards. These boards will, in time, cup. If we cover the former outside of the boards with sheet metal, the cupping action will stretch the metal very tightly to the boards. This will allow the use of thinner metal and it will become almost a part of the board, like a very heavy coat of enamel, but will make the board stronger. Using thinner metal will lower the cost and, for instance, will bring the cost of a copper roof to a more affordable level. A new roofing product is born that can be permanently set to its rafters without visible nails, and is even lower cost because the need for plywood is eliminated, and if the roof is copper, it will endure for many decades. Similarly, thinner sheet metal, or aluminum, covering can be used on siding. If the metal has a baked on enamel finish, maintenance costs can be avoided for many decades. Metal covered siding cannot breath. Moisture from the inside the home can condense between the metal and the wood siding, as it does when it causes paint to blister. Rot actually often occurs underneath paint. To insure against this incipient problem, ventilation must be built into the wall between the siding and the insulation. My invention is further extended to teach how to do this. Outside

walls are ventilated in the colder regions of Germany and Japan, so this is not new. Venting is often from holes near the ground level and out through holes at the eave. Grass fires have, in some instances, entered the house walls through ground level vent holes and by chimney effect, have run up inside the walls and destroyed the house. My idea is to take the air from a crawl space, or cellar, and vent it up through the inside of the outside walls and into the attic space, which is always ventilated (or we could be in trouble with our moisture tight copper roof). If radon gas is present in the crawl space, it will also be ventilated around the living cocoon, as would never ending ground moisture evaporation.

Metal siding and roofing are often disliked because of their tinny sound when touched, or hit, by anything. Even wind makes it rattle, and in time, the sheets tend to work loose and allow the weather in. Hail is particularly noisy. When the metal is thin and stretched tight to the cladding, it does not rattle and even when thumped with the fist, it sounds like a solid timber, as no tinny or metallic sound is heard. The combination of wood and tight metal has a high quality feel and appearance, particularly when the roof is copper and the siding is aluminum with richly colored baked on enamel finish. Both last indefinitely. If the wood is, say, Douglas Fir, which has a hard surface, it will be very hard to dent or pierce the metal through misadventure. Perhaps, best of all, the metal covered siding, or roofing, is fire resistant.

The tendency for wood to cup when two pieces are sawn from a single piece can be turned to more useful purposes. Decking used outdoors can be designed so that its center is always bulged upwards so that it will shed water. Flat decking, or decking that naturally cups, will hold water,

which soon leads to deterioration of the finish and to rot. Log siding is made from square boards, which means a lot of the wood is wasted to make the curve. If cupped pieces are used, then less wood needs to be wasted to get the curved log-like appearance, and can be made from thinner wood. Similarly, clam shell casing is curved and the backside is partly plowed out to arch the casing over rough spots and make the edges fit tightly. This wastes wood. Cupped pieces would involve less waste, and can be made from thinner pieces of wood.

Log house walls use a larger volume of wood than framed house walls. Costs are lowered by using tree stems that are green and that are processed no further than debarking and corner notching. However, the weight factor of wet timber reduces the radius of acceptable delivery costs and the logs shrink, settle and check in an unacceptable way. Dead tree stems cut the weight and shrinkage problem, but produce faults like rot and incipient rot and vermin. It takes months in a kiln and many months in the air to dry freshly cut tree stems. Over the years and, in fact centuries, sawn, dried and planed squared timbers have, in many cases, taken over from round logs. High quality homes, built of cedar, redwood and white oak, as well as lower cost pine, spruce and fir, have appeared in Europe and North America, usually using 4" thick tongue and groove planed, kiln dried timbers.

In the U.S. and Canada, authorities are faulting these timber houses because 4" nominal, or 3 1/2" actual, wall has not enough insulation value. Simply making the walls thicker is just too expensive, especially with the richer quality woods. My invention envisions a wall built of two 2" planks locked to each side of the key like stud, previously disclosed. This produces a cavity to take insulation and hide electric wiring. It is an axiom that

two 2" planks, good on one side, are considerably less costly than a 4" plank, good on both sides. They are so much easier to come by out of the tree, and 4" takes four weeks to kiln dry and 2" takes one week. The composite 2" plank and stud wall can be produced at comparable cost to the solid 4" wall. The cost of the wall can be further reduced by using lower cost pine planks on the inside (which are whiter and brighter) than, say, cedar or oak on the outside. In some rooms the inside planks can be left out all together, and very inexpensive gypsum drywall can be used attached directly to the studs. This cavity wall timber house can be built to look exactly like a 4" timber house. I have invented a Danish type notch corner finish, or a Russian style timber corner post can be used to complete the corner. The insulation factor can be raised from R-7 for 3 1/2" of timber wall, to R-26 for an 8 1/2" cavity timber wall (R-11 is required in most areas). No nails will show, and the 2" planks can be curved to simulate a log wall. Square studs that fit tightly between the inside and outside planks and nailed in with hidden nails, as is the siding, can be used to frame doors and windows; also corners and partition junctions, these usually cannot be placed exactly where key locked evenly spaced studs occur.

25 Brief Description of the Drawings

Figure 1 shows a piece of raw lumber rough sawn to approximately 2 7/8" X 7 7/8" usually referred to as a rough 3x8. Moisture content is 30%, or more.

30 Figure 2 shows a 3x8 that has been kiln dried for approximately 12 days. The shaded area has a moisture content of approximately 20%, and the clear area has a moisture content of approximately 12%.

Figure 3 shows that the wood has been planed to pattern for an overall size of 2 5/8" x 7 1/2" and the

outer faces and the outer tongues have been covered with sheetmetal. The center of the timber is still wetter than the outside area, as is indicated by the shaded and clear areas.

5 Figure 4 shows that the timber has been diagonally resawn to form two pieces of sheetmetal covered bevel siding or roof boards, and further shows that the wetter area has been exposed.

10 Figure 5 shows a simple piece of metal covered bevel siding or roof boards with an exposed wetter inside that is beginning to dry. This, as is indicated by the arrows, is causing the wetter side to shrink, forcing a bend to the whole piece of siding which, in turn, is causing the dry surface to arch which stretches the sheetmetal very

15 tightly to the surface of the siding.

 Figure 6 shows the piece of sheetmetal bevelled siding has become thoroughly dried out with the resultant bowed shape. The piece of siding has been cross grooved on its rough side, as is indicated by the dotted line.

20 Figure 7 shows a sample of a wall which has sheetmetal covered siding locked onto special studs with gypsum board nailed to the inside of the special studs.

 Figure 8 indicates a cross section of the wall noted in Figure 7, which shows the metal covered siding locked

25 to two special studs. Drywall inside cover is also indicated.

 Figure 9 shows a piece of siding or roofing posed over a special stud or rafter. The siding has a cross groove that is the same pattern as the end of the stud. The end

30 of the stud is slit.

 Figure 10 shows the stud being forced into the groove in the siding. This has caused the slit in the stud to close together as the outer lips of the stud pass the inner lips of the groove.

Figure 11 indicates a permanent locked joint between the siding and the stud reinforced by nails and by glue within the joint. Gypsum board inside finish has been supplied and the inside of the wall has been insulated.

5 Figure 12 shows a similar permanently locked joint as in Figure 11, except that 2 slits half the width of the single slit in Figure 11 have been employed. The application of the siding to the studs is easier, as there is less wood to bend and conversely with the depth, the slits into the stud can be reduced enabling the use of a smaller
10 dimension stud, say 2x3 instead of 2x4.

Figure 13 shows that by using 2 slits instead of 1, the width of the male member can be increased without changing the ease of assembly. Here a 4" wide floor beam
15 is shown, with an outside 2" decking supplied, using larger nails. Caulking is applied into the slits between pieces of decking so that water cannot get into the slits.

Figure 14 shows a raw piece of 4x6 timber that has not been dried, similar to Figure 1.

20 Figure 15 is similar to Figure 2 except that a 4x6 timber is used that has been dried on the outside, but not on the inside.

Figure 16 shows how the timber of Figure 15 has been planed to pattern with grooves on the edges for future
25 nails.

Figure 17 shows the same piece having been resawn into two similar pieces of 2x6 decking with their wet inside area exposed.

30 Figure 18 indicates a finished piece of 2x6 decking that has become completely dried and which has become bowed so that it will shed rain water. Also, a cross groove, as indicated in Figure 13, has been plowed across the resawn face of the decking or its underside. This is indicated by the dotted line across the piece of decking.

Figure 19 is a cross section of Figure 18 showing a multiple application of decking applied to the joist. The use of nails is indicated, which are hidden from view from above. Also, caulking is shown which keeps water out of the slits in the joists.

Figure 20 is a cross section of an outside wall showing log siding locked on to both sides of a stud.

Figure 21 illustrates the top view of the end of a log, for log home construction that has been notched for log home corner construction, using what is termed in the trade to be a Danish notch. The width of the notch measuring in both dimensions (across the sides of the notch and between the shoulders of the notch) is the same dimension as the measurement across the special wall studs from shoulder to shoulder. This is shown in Figure 20 and 21 as No. 35.

Figure 22 shows how the end of the log in Figure 21, which has a Danish notched corner, has been shortened into a stub Danish notched corner. The height of the log is not reduced, but the sides of the log inside of the notch have been reduced to the same dimension as the notch width, leaving enough shoulder to make a strong cornerlock and to receive log or plank siding, which has its ends bevelled to 45 degrees to conform with the former shape of the log.

Figure 23 shows a side view of the same longer log s indicated in Figure 21. As is the case with Danish corners, the depth of the notches are 25% of the height of the log, and the width of the notch is the same as the inside dimension of the proposed cavity wall, as indicated by No. 35.

Figure 24 is the shortened stub corner viewed from the side, and it can be particularly noted that the plane of the inside shoulder is the same as the notch.

Figure 25 is a side view of a plurality of stub corner logs that have been assembled and to which log siding has been applied to simulate logs. The appearance is exactly the same as a log home with Danish corners. The log siding is exactly the same face shape as the corresponding stub log and exactly in line.

Figure 26 is the top view of my new log house corner which shows the interlocking stub logs and the log siding inside and outside, held together with locking studs with no visible nails inside and outside, masking the fact that it is log siding and not true logs. Also illustrated is how a window or door can be framed using ordinary studs which can even be face nailed in because the nails will be hidden by the window casing inside and out. However, nails hidden in the tongue and groove as shown are better to avoid rust. The stub logs are shown to be firmly spiked together vertically.

Figure 27 is an isometric side and top view of my new log building, which more clearly shows how the various parts are locked, nailed and glued together without visible nails. It also clearly illustrates that this cavity construction looks exactly like a log house with Danish corners.

Figure 28 shows two stub corner logs poised one over the other as if they are about to be set into the assembly shown in Figure 27.

Figure 29 shows how a standard window and door casing or molding, indicated by dotted line, is cut from a 13/16" piece of dry wood.

Figure 30 shows the same piece of trim as in Figure 29.

Figure 31 shows a raw green (or wet) piece of wood.

Figure 32 shows the same piece that has been kiln dried, but that still has a wet inside.

Figure 33 shows how Figure 32 has been resawn into 2 pieces, exposing the wet inside.

5 Figure 34 should be compared to Figure 29 as it shows how a similar molding can come from a piece of wood that is 9/16" thick, as compared to a 13/16" thick board used in Figure 29.

10 Figure 35 shows a completed dry molding, which is of the same appearance as the molding in Figure 30. The wood is thoroughly dried first, which will cause it to cup. Then the molding is planed so that all moldings will be uniform.

Figure 36 is a raw green and rough piece of 4x8 timber.

15 Figure 37 is the same timber after being kiln dried, but which still has a center that is wet, or at least wetter than the outside surfaces.

Figure 38 is the kiln dried timber after it has been planed to a double log siding pattern.

20 Figure 39 shows the result of resawing of the 4x8 double molding to two pieces of 2x8 siding, each having a wet side revealed.

25 Figure 40 shows one of the pieces of log siding that has become thoroughly dry. This has caused the underside to shrink and forced a bow into the siding, giving it a greater round log look as if it had been planed out of a piece of lumber greater than 2x8. The dotted lines across the siding indicate cross grooves have been plowed out of the arched piece of log siding, enabling it to be locked onto the special studs already explained.

30 Figure 41 shows two pieces of bowed log siding clamped onto the special studs, which exactly fit into the locking cross grooves across the back of the log siding.

Figure 42 illustrates a piece of cladding that is locked onto a stud that has its center area containing

more moisture than its outside area.

Figure 43 shows what can happen when the stud shown in Figure 42 is thoroughly dry. The wood inside the slit shrinks when it becomes dry and the two lips cup inward unlocking the joint and causes the locking system to fail. This occurred during field tests.

Figure 44 illustrates the use of a stud in the center of the cross groove to prevent the lips from turning inward and unlocking. The stud is triangular so as not to be in the way when the stud is forced into the groove.

Figure 45 shows the position of the two lips of the stud reversed. The locking lips have been made on the slit side and the outside of the lips have been sloped. The triangular shape of the stud inside of the groove has been shaped to exactly receive the lips inside the slit. Now as the wood dries out thoroughly, any action of the lips to bend inward will more firmly lock the lips onto the stud inside the groove and strengthen the joint. The center stud within the groove in Figure 44 and Figure 45 make the lock joint more resistant to sheer by preventing any movement of the lips under sheer strain.

Figure 46 shows that when the stud has two slits instead of one, the lips are composed of drier wood and, therefore, there can be no inward bending of the two lips of the stud, or male member.

Figure 47 shows how Figure 46 can be further improved by introducing two triangular studs into the groove. This will strengthen the joint against sheer pressure and it will be impossible to move the stud in the groove unless there is pressure at the same time to withdraw the stud from the groove. Nailing and gluing will prevent the stud from being withdrawn.

Figure 48 shows a cross section through the gable of a building that has sheet metal covered roofing and

sheetmetal covered bevelled siding. Walls with sheetmetal covered wood siding, or even with heavily enameled wood siding, need ventilation directly behind the siding to prevent water vapor from inside the building being forced through the siding and condensing between the metal or enamel covering and rotting the siding. The main feature of this cross section is to show how water vapor from inside the house can be vented up into the roof cavity and out through the very necessary roof vents. The drawing also illustrates how water vapor from the ground or cellar, and radon gas from the ground, can be ventilated out of the building. Electrical wiring in the vent space is also shown. There is a thin sheet of wallboard that positively prevents the insulation from bulging out and blocking the vent space. However, this is not necessary if the insulation is carefully installed and if the thickness of the insulation is definitely less than the thickness of the wall cavity.

Figure 49 shows a cross section of a building at the eave, and further illustrates my method for venting water vapors at the inside of the outside of the metal covered bevel siding to the outside of the building. The water vapor from inside the building is shown rising up the ventway by chimney action which, in turn is sheltered by the eave from rain. This drawing further illustrates how air is drawn from the outside into the crawl space area. It also shows how ground water vapor and possible radon gas are drawn around joints in the vapor barrier ground cover. Here roof venting is shown to be independent of wall venting, but roof venting is shown taking away water vapors that pass by or through the roof insulation.

Figure 50 illustrates how water vapor from inside a house with a concrete slab floor can be vented outside by means of an air raceway next to the inside of the outside

metal covered siding. This is accomplished using vent holes through the siding between each stud and at the bottom and top of the wall or under windows that bridge across stud spaces, as shown in this drawing. These vent holes are open to rain and are protected by triangular shaped rain protectors, which include screening against insects.

Figure 51 shows the process of manufacturing the vent hole protectors, and includes a piece of sheetmetal that has been stamped out as illustrated with lines showing metal bending lines and punched nail holes.

Figure 52 is a bottom view of the vent hole protector and also shows the anti-insect screening.

Figure 53 is a face view of the vent hole protector. Dotted lines in the face of the drawing indicate a hole in the wood siding.

Figure 54 is a side view of the vent hole protector, which also shows the screening and the nails for application.

Description of the Preferred Embodiments

(1) indicates raw, undried wood. (2) indicates dried wood. (3) shows tongues that have been planed into the wood. (4) indicates sheet metal covering. (5) shows a handsawn resaw cut, which has diagonally split the timber into two bevelled boards. (6) indicates the path of the cross groove across the siding. (7) indicates the bowed surface of the siding, or roof board, after it has been thoroughly dried. (8) indicates the shoulder of the stud. (9) is a stud with a slit and locking edges. It also has drywall applied to it. (10) is gypsum, drywall interior house finish. (11) is fiberglass insulation. (12) is the actual slit in the edge of the studs. (13) are nails. (14) is glue applied between the siding and the stud. (15) is a larger nail, or spike. (16) is a heavy floor

joist, as opposed to a stud. (17) is a groove planed into the edge of the decking to receive and hide the nails. (18) is caulking applied into the slits in the joist between pieces of decking to keep rainwater from getting into the slits and causing decay. (19) is 2x6 decking specially manufactured to lock onto its joists. (20) is a special wall stud that has both edges modified to lock into its cladding. (21) is a cladding called log siding, which has been modified to lock onto studs. (22) is the locking lips of the special stud. (23) is the 45 degree bevelled part of the Danish notch. (24) is the rounded surface of a log. (25) are vertical holes bored into logs and butt logs to receive assembly spikes. (26) are the flattened surfaced of the logs, top and bottom. (27) is a standard 2" wall stud that is used to frame in window and door openings and at corners. This stud may be trimmed in width to exactly fit between the inside and outside siding. (28) shows a door or window jamb. (29) is a window or door casing that covers a joint and hides the nails that attach the inside liner to the standard stud. (30) is either the top or bottom surface of the inside of a Danish notch. (32) is the side surface of the inside of the Danish notch. (33) is the top shoulder of the Danish notch. (34) is the bevelled side shoulder of the Danish notch. (35) is the width between the inside log finish and the outside log finish, which is also both dimensions of the top of the notch. (36) shows a strip of wood that is wet on one side and the dotted lines indicate the amount of wood that will actually be used to make a molding. (37) shows the larger size of molding that can be planed out of strip 36 after it has been dried and becomes bowed. (38) as opposed to detail (21) shows a bowed piece of log siding. (39) as opposed to detail (9) is a stud that has a wet interior. (40) is a triangular

stud within a cross groove. (41) is a reversed locking lip
of a stud. (43) is water vapor from inside the heated
house. (44) is water vapor from the ground. (45) is
radon gas. (46) indicates the special lock stud. (47) is
5 a locking rafter. (48) is metal covered bevelled siding,
or roofing. (49) concrete. (50) subflooring. (51) 2x6.
(52) is 2x4. (53) is a glue laminated beam. (54)
electric wiring. (55) is 4/12 wedge mould. (56) is wood
ceiling finish. (57) is a wood truss. (58) is a treated
10 2x6 wood sill. (60) is the vapor evacuation vent. (61)
brace between truss and rafter. (62) 4x6 post. (63)
bypass area between floor joists. (64) Bypass area
between studs and floor joists. (65) vent hole in
concrete wall. (66) screened louvered foundation vent.
15 (67) earth. (68) 2x10's. (69) eave vent. (70) living
space. (71) crawl space. (72) outside air. (73) 1/4"
waferboard. (74) 1x4 boards. (75) air vent cover. (76)
air vent cover, front. (77) air vent cover, side. (78)
nailing strip. (79) nailing holes. (80) air vent
20 screening. (81) air vent hole in siding.

CLAIMS

1. An interlocking dovetail joint between two 2x6 planks set so that the face of the first plank lies edge to edge across the edge of the second plank at 90 degrees so that the dove-tailed shaped groove across the first plank, which is accomplished by having rounded 1/16" grooves cut lengthwise across the faces of the second plank near one edge, and having the groove across the first plank undercut on each side to receive the edge of the second plank with the depth of the groove on each side of the second plank being the same as the undercutting of the cross groove in the first plank, with the second plank having a slit cut lengthwise in the center of its grooved edge, the depth of the slit being about the same as the thickness of the plank and the width of the slit being slightly greater than the combination of depth of the two (1/16") face grooves, which permits the second piece to be withdrawn from the first piece by squeezing its slit ends together and pulling on the second plank and conversely the outside corners of the slit edge of the second plank are slightly rounded, as are the edges of the groove across of the first plank so that the first plank can be lightly hammered by using a wood mallet to force the groove of the first plank over the slit edge of the second plank, producing a locked joint.

2. A locking joint between two planks, as described in Claim 1 except that the first plank is tongue and groove cladding and a nail has been driven from the inside corner of the outside shoulder of the tongue through the first plank and into the second plank, which will prevent the first plank from sliding along the edge of the second plank, also reinforcing the joint with the head of the nail being hidden in the tongue and groove configuration.

3. An interlocking joint between 2 planks, as in

Claim 1 except that the plank sizes would be different than 2x6 and other exact dimensions referred to proportionately varied.

5 4. An interlocking joint between two planks, as described in Claim 1 where the second plank has two slits cut into its edge, which are half as wide as a single slit might be and which are positioned close to the face of the plank so that forced jointing can be accomplished.

10 5. An interlocking joint between two planks, as described in Claim 1 where glue is used to lubricate the jointing process and remains to make the joint much stronger, especially against shear forces.

15 6. An interlocking joint system, as described in Claim 1 where there are a number of evenly spaced second planks on the same plane, like house studs, onto which one at a time, a series of first planks with a plurality of cross grooves at the same spacing as the second planks are forced and locked onto the plurality of cross grooves at the same spacing as the second planks are forced and
20 locked onto the plurality of second planks, making a very strong shear panel.

25 7. An interlocking joint system, as described in Claim 1 where the second plank has both edges dovetailed so that cladding can be applied to both edges of second planks in a stud-like series of the second planks, forming a cavity wall that can hold insulation.

30 8. A corner system between two cavity plank walls, as described in Claim 7 where the corner is formed by mitering the inside and the outside planking 45 degrees, using ordinary square edge (or S4S) studs to frame the corner using nails hidden in the tongues and grooves of the planks.

9. A corner system between two cavity plank walls, as described in Claim 7 which has the same outside

appearance as a Danish notched corner, but unseen on the inside the corner timbers have been cut to short stud timbers approximately 20" long, which contain the Danish notches, with enough inside side shoulders to firmly lock the stub timbers together except that the inside shoulders are cut off to the same level as the side notch and to the same thickness as the width of the cavity between the inside and outside planks in the walls, as described in Claim 7 which allows the outside planks of the wall, when cut to 45 degrees, to snugly fit the notches in the cross stub timbers and to be secretly nailed to its corresponding stub timber at its planed off shoulder area and at the same level which will make it look exactly like a regular timber wall with Danish notched corners, similarly the inside planks are mitered at 45 degrees and are set offset so that they only lap half of the opposing corner planks, as in a Danish corner, producing as corner joint between two cavity plank walls that look exactly like a Danish corner.

10. A cavity wall and corner system, as described in Claim 9 where the planks are tongue and groove log siding and the stub corner timbers are rounded at their sides to match the log planks at their same level.

11. A plank described as the first plank in Claim 1 is sheet metal covered with a waterproof jointing means, as taught in my U.S. patent number 4,065,902, except this planking is bevelled and has been diagonally resawn out of a thicker oblong plank, which is wetter in its middle than on its surface, and which has been planed into a pattern having three tongues and two grooves opposing each other on each edge and being of similar dimensions, except that the grooves are slightly larger than the tongues, and also having the outer faces tightly covered with sheet metal, which is locked firmly around the outer tongues with the

diagonal resaw cut being made from the top of the center tongue on one edge to the underside of the center tongue on the opposite side, such saw cut exposes the wetter inside of each metal covered bevel plank, allowing the
5 freshly exposed surface to dry and shrink, which causes the other metal covered side to bulge, stretching the sheet metal more tightly to the wood, making it thin, almost like a thick coat of enamel paint, with any defects or bumps on the surface of the wood showing on the surface
10 of the metal.

12. A plank that is similar to the plank in Claim 11 except that the sheet metal is thin copper.

13. A plank that is similar to the plank in Claim 11 except that the sheet metal has been covered with a coat
15 of permanent finish.

14. A log siding plank, as described in Claim 10 that is initially resawn out of a timber twice its thickness, which has a wet center, as described in Claim 11 except that the planks are planed into tongue and groove log
20 siding after the exposed inside has thoroughly dried out, and the planks have done all the bulging possible, which will produce log siding that is more rounded than would have been produced from planks that have been manufactured initially to half the thickness of the thicker plank.
25 Such log siding has cross grooves cut on their underside so that they can be locked onto special studs, as previously claimed.

15. Outside floor decking that is initially resawn out of planking twice its thickness, which has a wet
30 center, as described in Claim 11. Said decking is planed after it has had its resawn surface thoroughly dried and its top bulged as much as possible, producing a deck board that is crowned on top that will shed rain water if the planks are spaced slightly when locked on to bearing

joints, as previously claimed, with caulking applied in the slits of the locking joints between planks to keep water out of the slits and having nailhead sized grooves cut on the sides of the decking to accept nails so that no surface nailing is needed.

5
16. Rounded inside door and window trim that is initially resawn out of lumber that is twice as thick as the lumber in the molding, and which is wetter inside than it is outside, as described in Claim 11. Said molding is
10 planed after the wetter resawn surface is thoroughly dry and the top surface has fully bulged, producing a round top molding that uses less lumber than it would have if it were planed out of lumber that was initially thoroughly dry throughout.

15
17. Ordinary stud material available on the market is often wetter on the inside than it is in its outer surface areas, and if it is turned into the second plank configuration as described in Claim 1 the split will expose the wetter wood which, on drying, will cause the split
20 ends of the stud to turn inward towards each other and could destroy the effectiveness of the locked joint, which can be prevented by the introduction of a triangular stud in the middle of the cross groove of the first plank, with similar angular corners cut out of the tips inside the
25 slit, which are formed so as not to be in the way during assembly, but exactly fitting when the assembly is completed.

30
18. The problem explained in Claim 17 can also be solved by switching the configuration of the split edges of the studs so that the locking lips of the second plank, as described in previous claims, are inside the slit instead of the outside, and the angular corner is on the outside instead of the inside of the slit, and similarly the cross groove of the first plank is modified so that

the sides of the center stud within the groove has locking lips matching the lips within the slit in the second plank, and the sides of the groove is sloped to match the slope of the angular corners of the second plank. Then, if there is any extra wetness exposed by cutting the slit, the cupping action will reinforce the locking action instead of weakening it.

19. The problem explained in Claim 17 can also be solved by having two slits cut instead of a single central slit, as the locking lips will be made of the outside dry wood and the inside wet wood would be neutral to the locking lips.

20. A locked joint, as described in Claim 19 where triangular studs are introduced in the groove of the first plank opposite to the twin slits in the second plank, and the second plank is modified to exactly match these pointed studs and still not block the assembly, making the joint even stronger against shear forces.

21. A system for venting to the outside warm water vapor from the inside of a heated building that passes through the insulation and the outside siding, and condenses under the paint on the siding, or on the metal if the wood siding is covered with sheet metal, which takes air from a ventilated crawl space under the living space or an unheated cellar, and passes it along the inside siding and delivers it to under the eave outside, which is accomplished by an open slit between the floor joints that reaches the outside wall, which extends to the foundation, with the studs bypassing the joints for a common footing such outside wall has its insulation clear of the inner surface of the outside siding, giving a clear path to the eave, where a slit between the top of the siding and top wall plate allows the most air to exhaust into the outside air.

22. A ventilation system, such as described in Claim 21 which also sucks moist air from the unheated crawl space by chimney action, which is caused by the draw from the heat from the heated area which has passed through, or
5 by the insulation going up along the wall to the eave system such crawl space air can contain both water vapor or radon gas from the earth.;

23. A ventilation system for a gable wall, similar to Claim 21 where the water vapor is exhausted into a
10 ventilated space under the roof.

24. A ventilation system for buildings built on a concrete slab, where the initial air is drawn through sheltered holes between studs at the base of the wall and is ventilated to the outside air at the eave, as in Claim
15 21.

25. A ventilation exhaust system that ventilates moist air from between studs under windows out through a protected exhaust hole, similar to Claim 24.

26. A pyramid-like sheet metal shield that covers the
20 vent holes in the siding, as described in Claim 24 but is open on the underside and is fitted with screening to protect the vent hole from the ingress of vermin.

FIG. 1

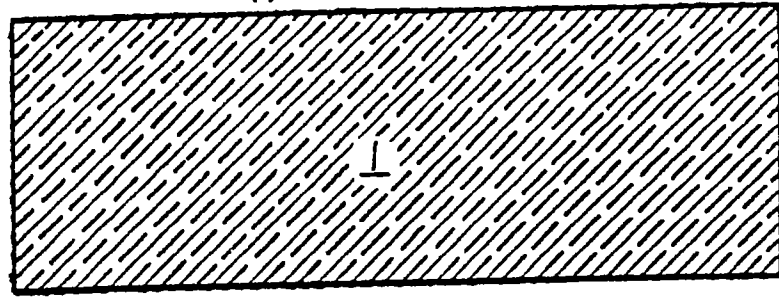

FIG. 2

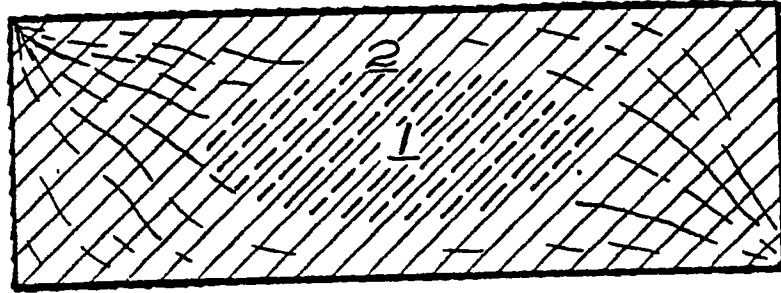

FIG. 3

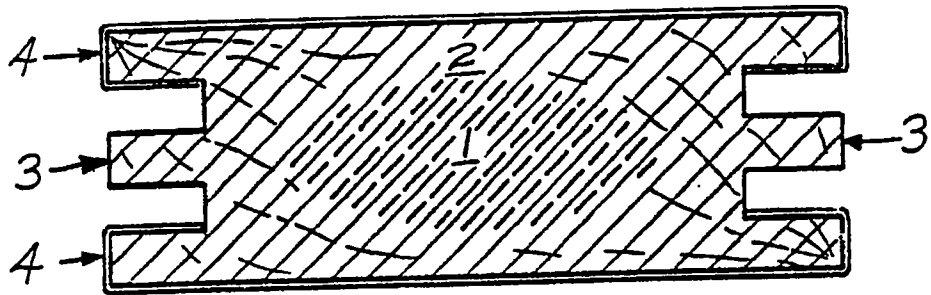

FIG. 4

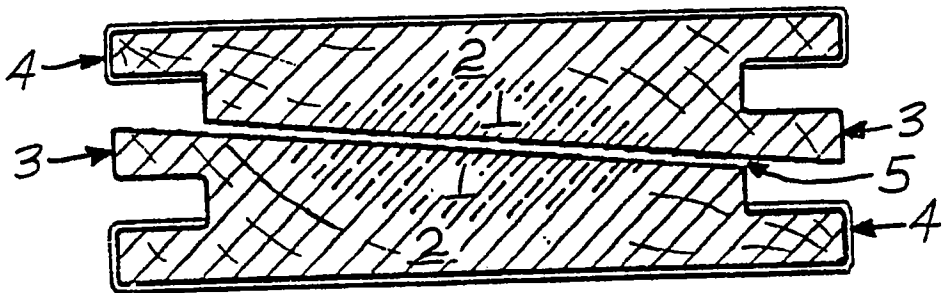

FIG. 5

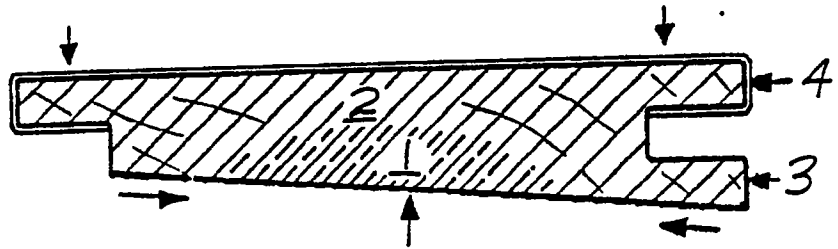

FIG. 6

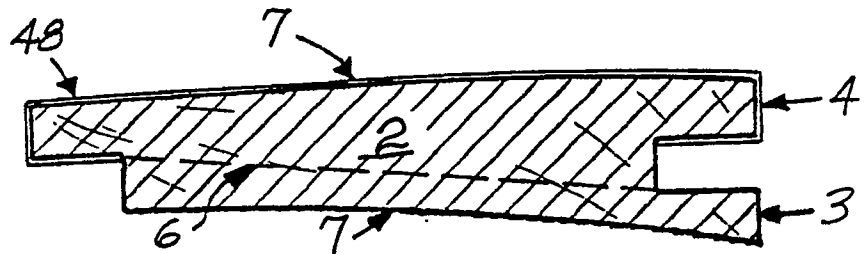

FIG. 7

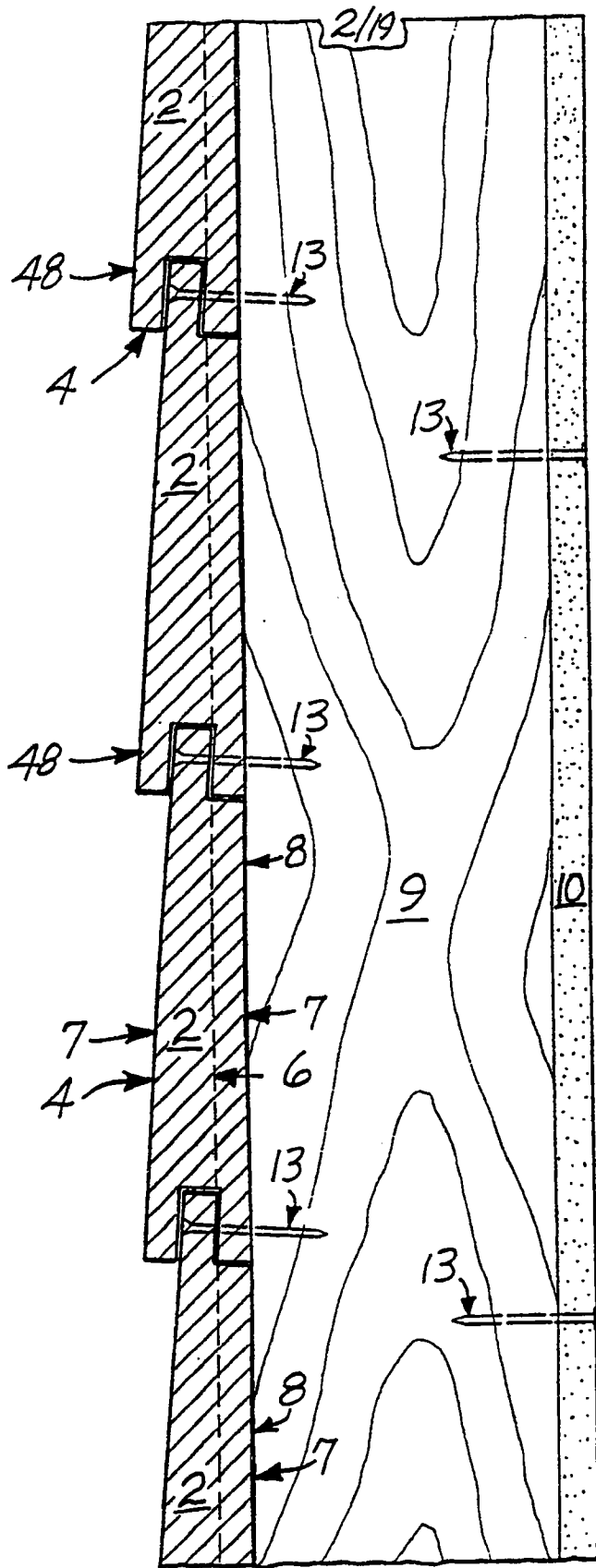

FIG. 8

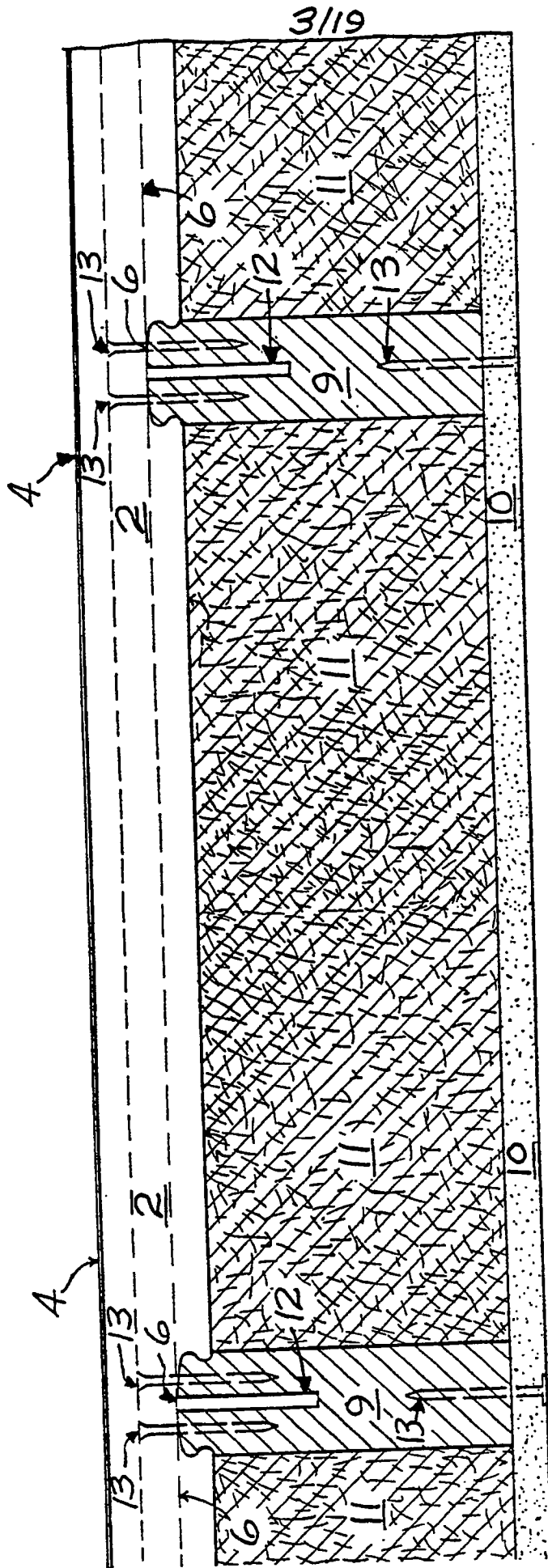

FIG. 9

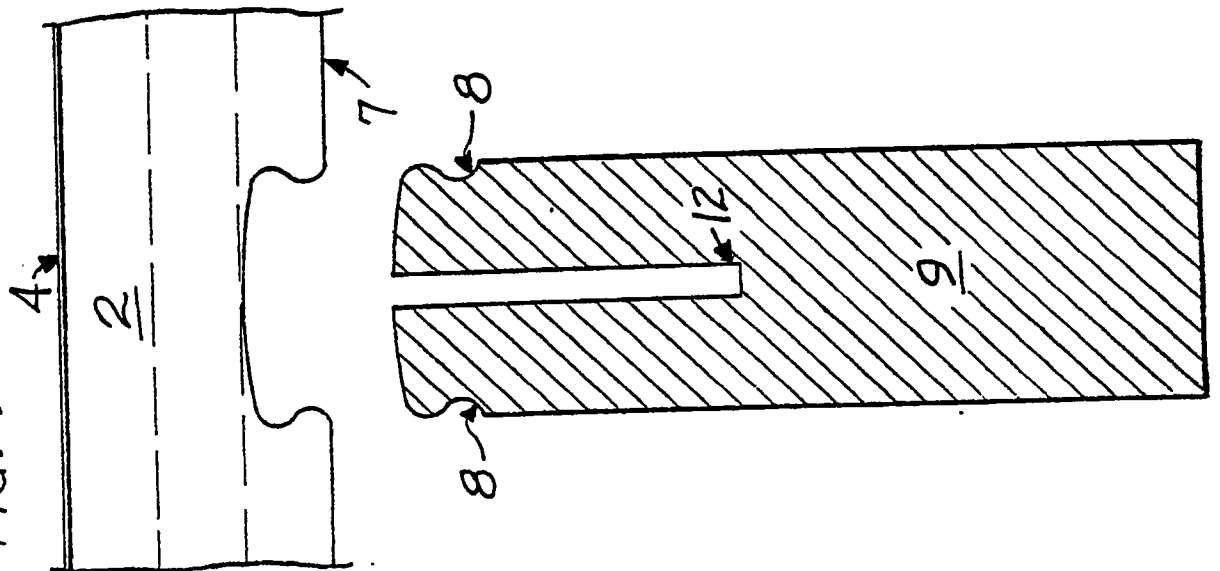

FIG. 10

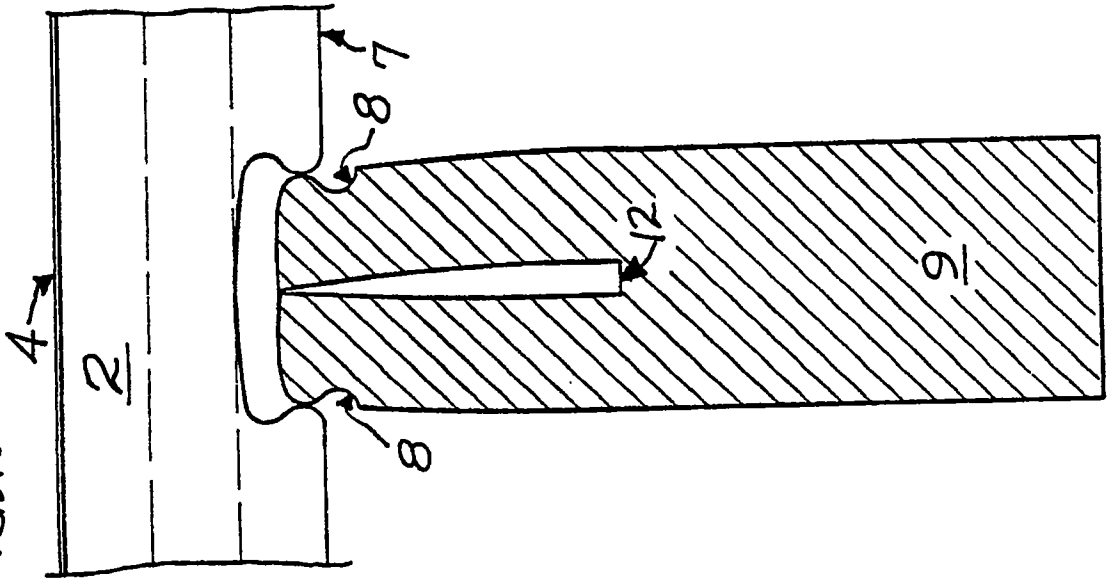

FIG. 11

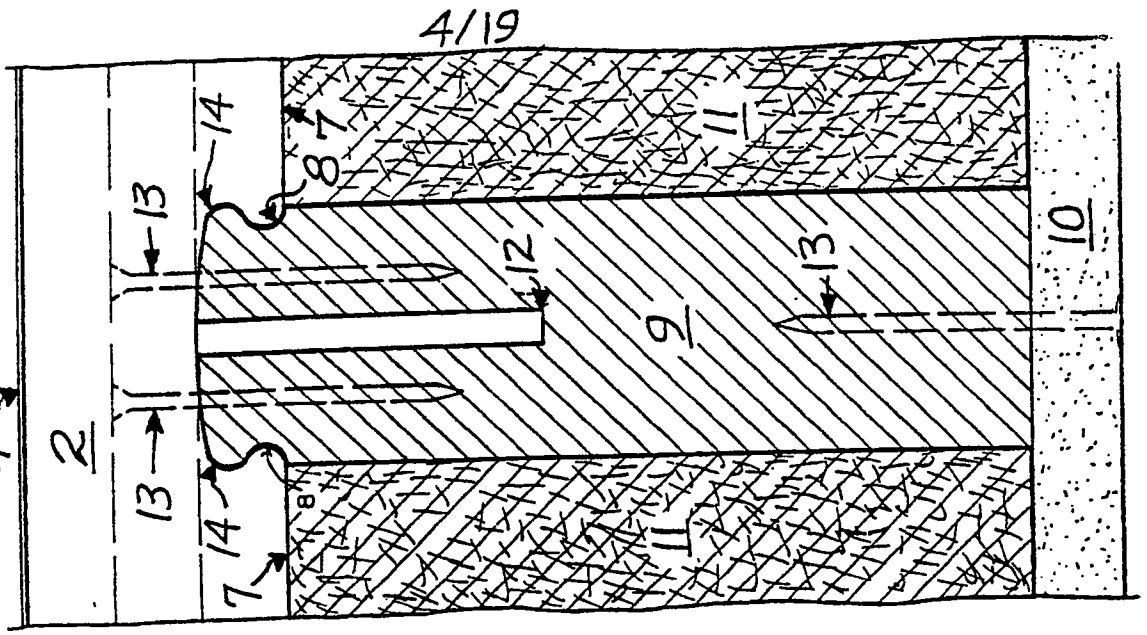

FIG. 13

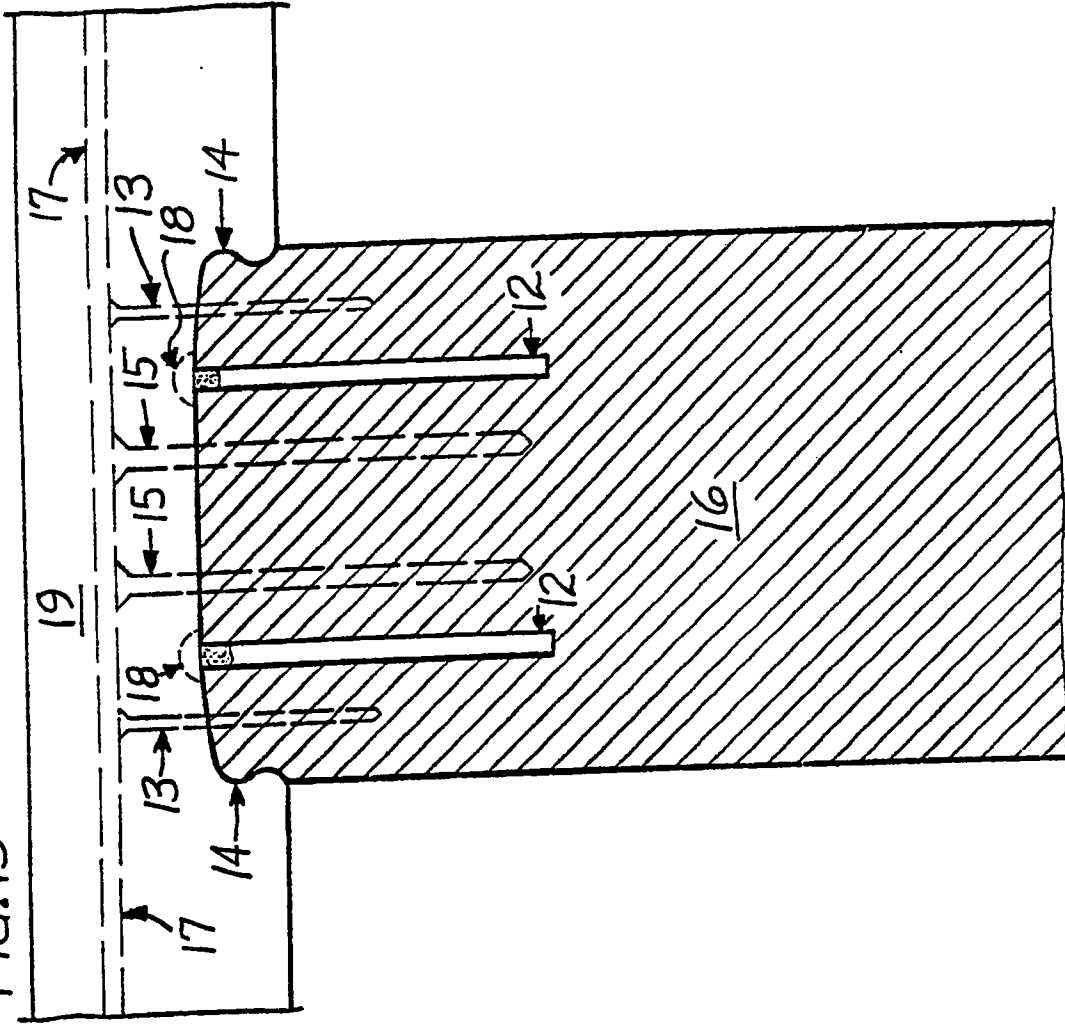

FIG. 12

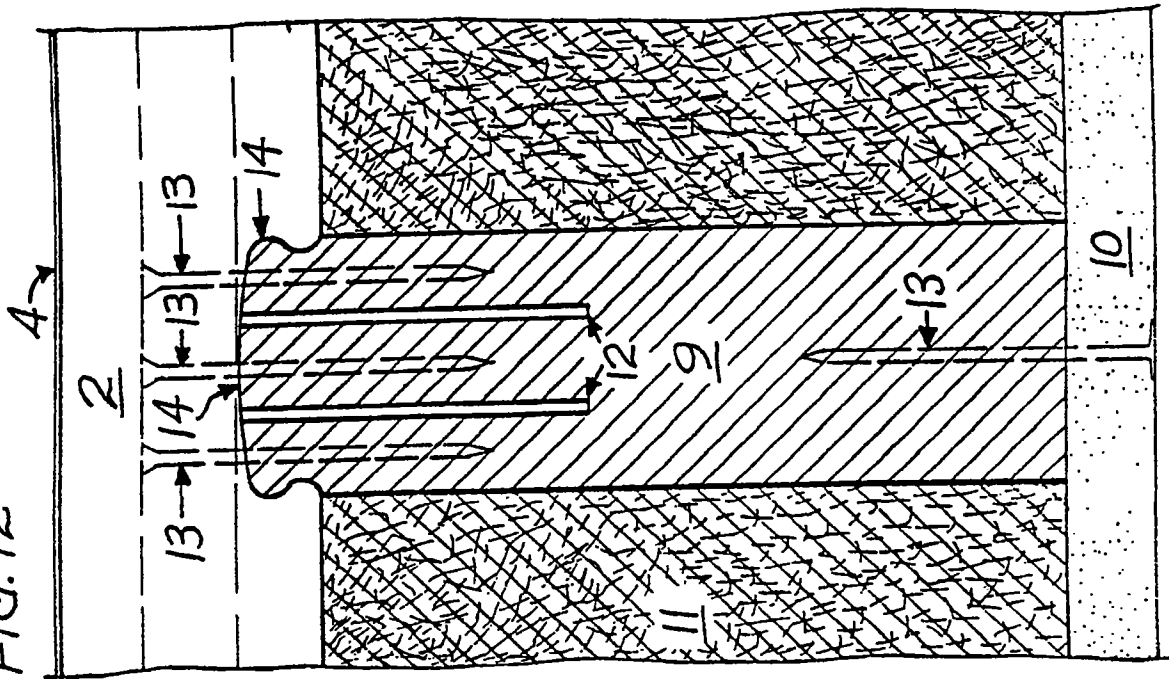

FIG. 14

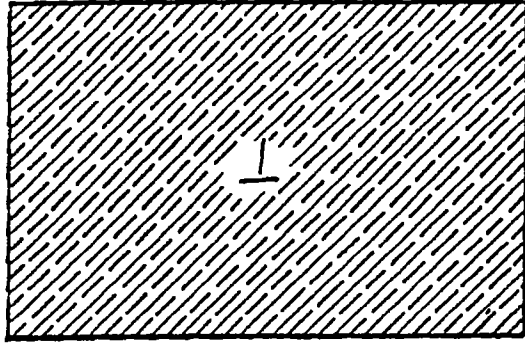

FIG. 15

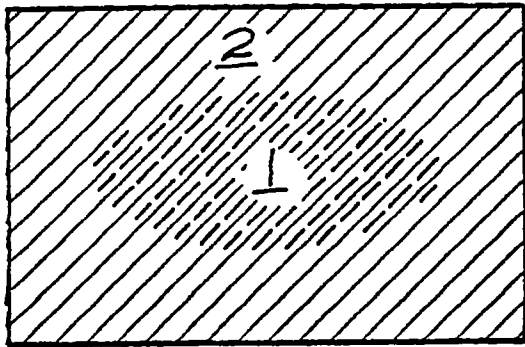

FIG. 16

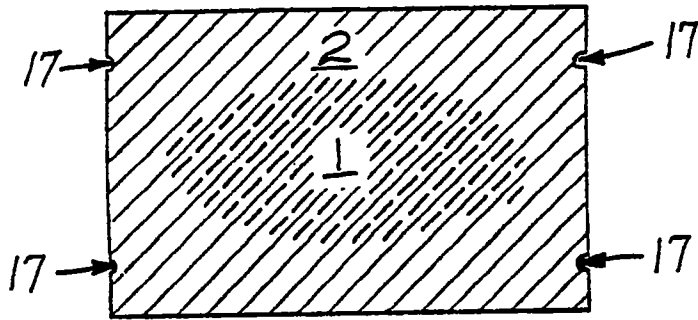

FIG. 17

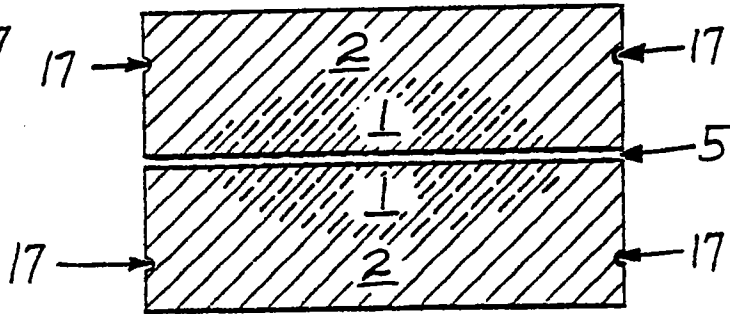
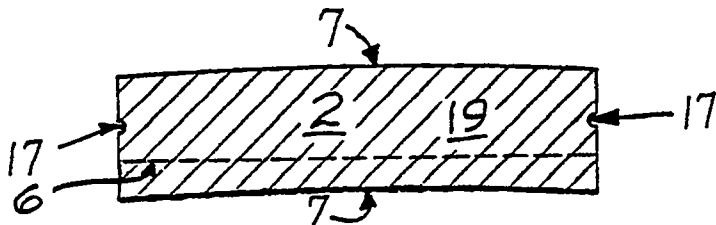

FIG. 18



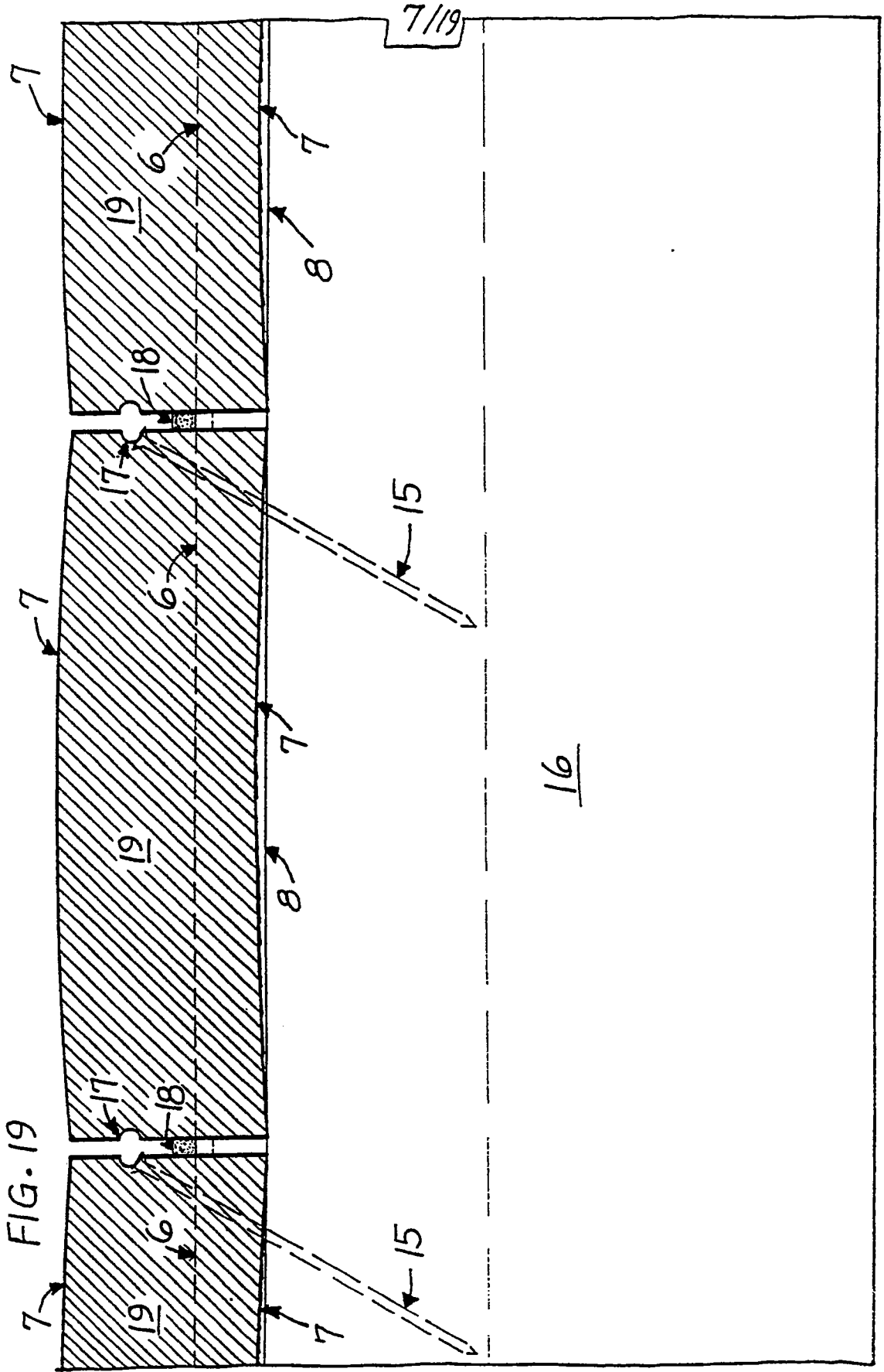
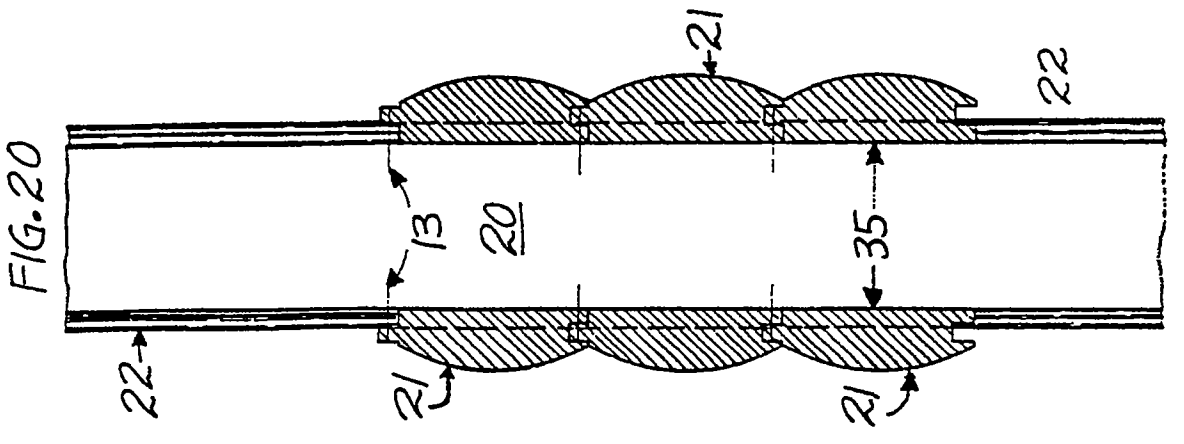
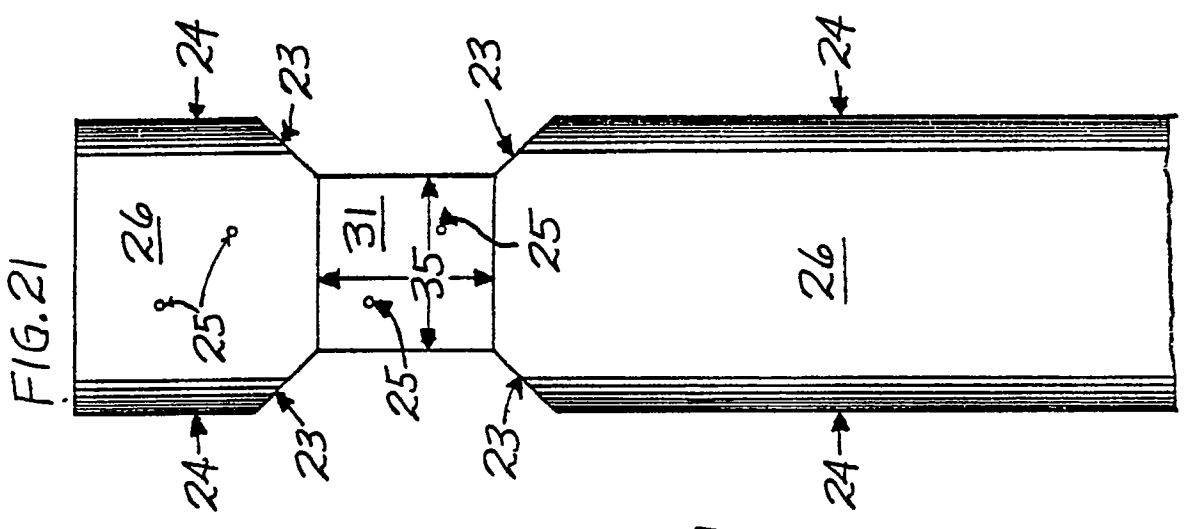
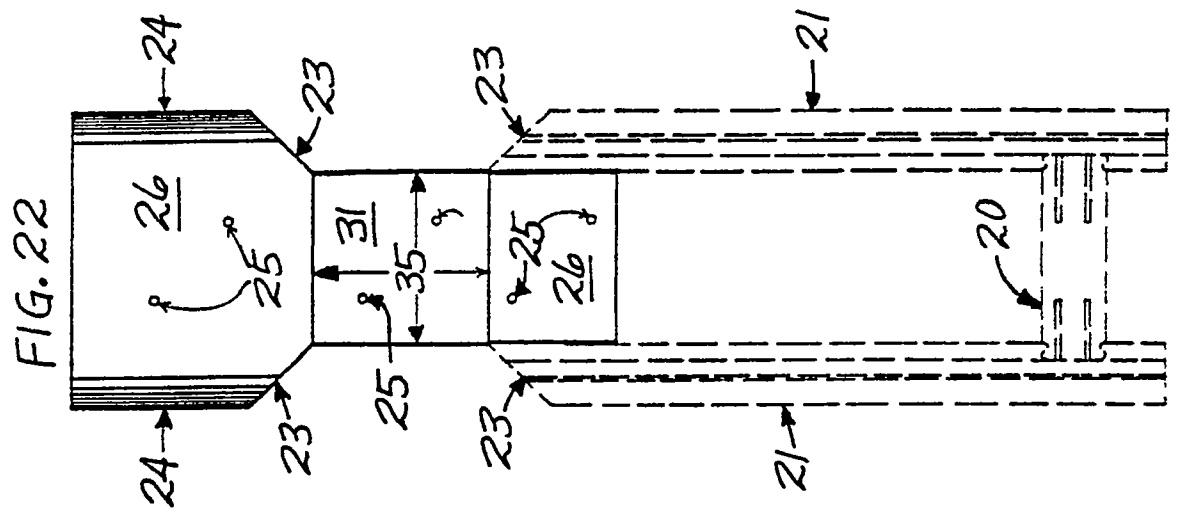
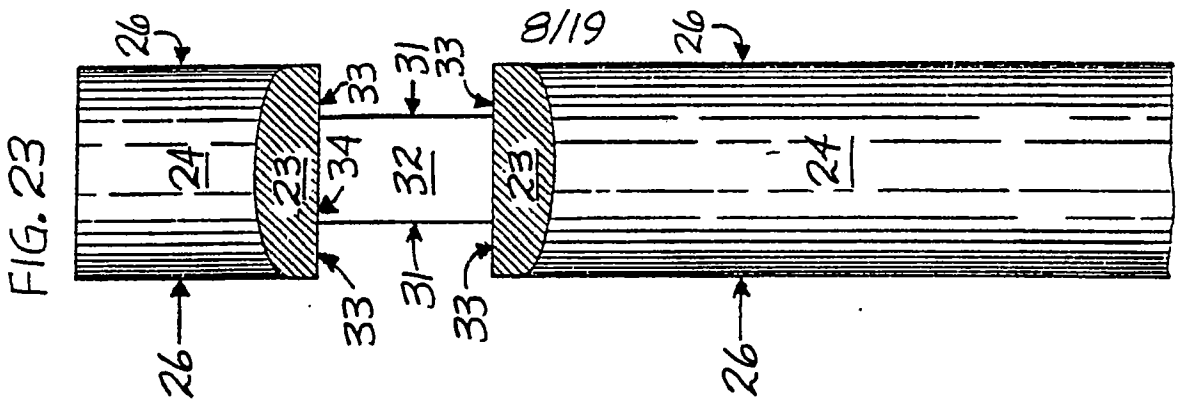

FIG. 19

16

7/19



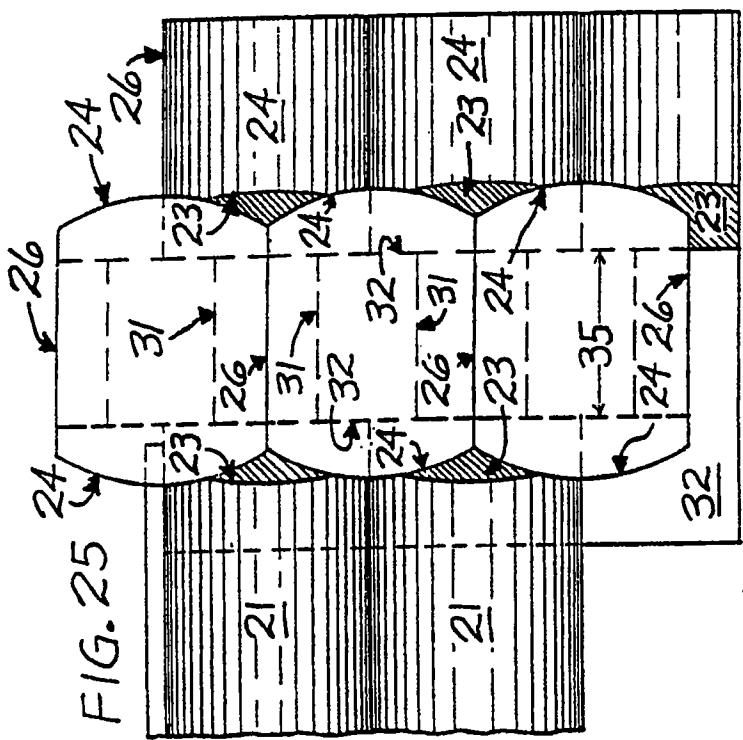

FIG. 25

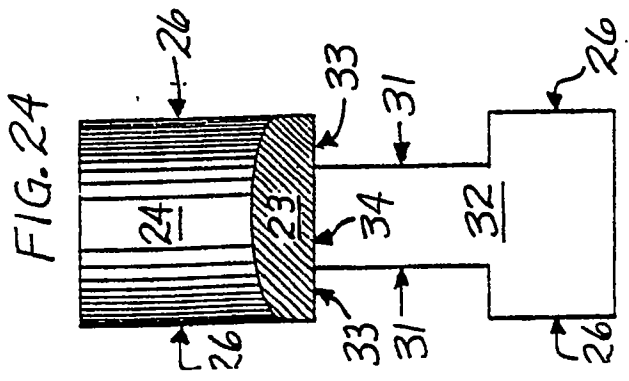

FIG. 24

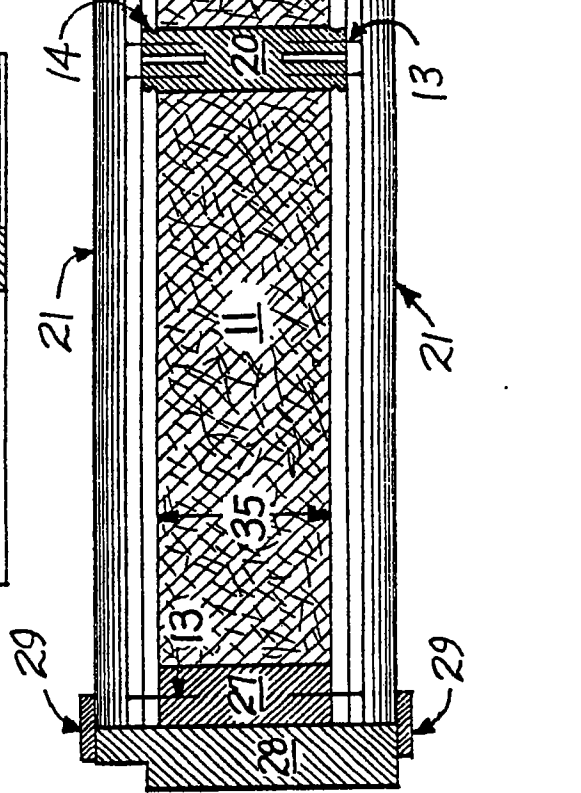
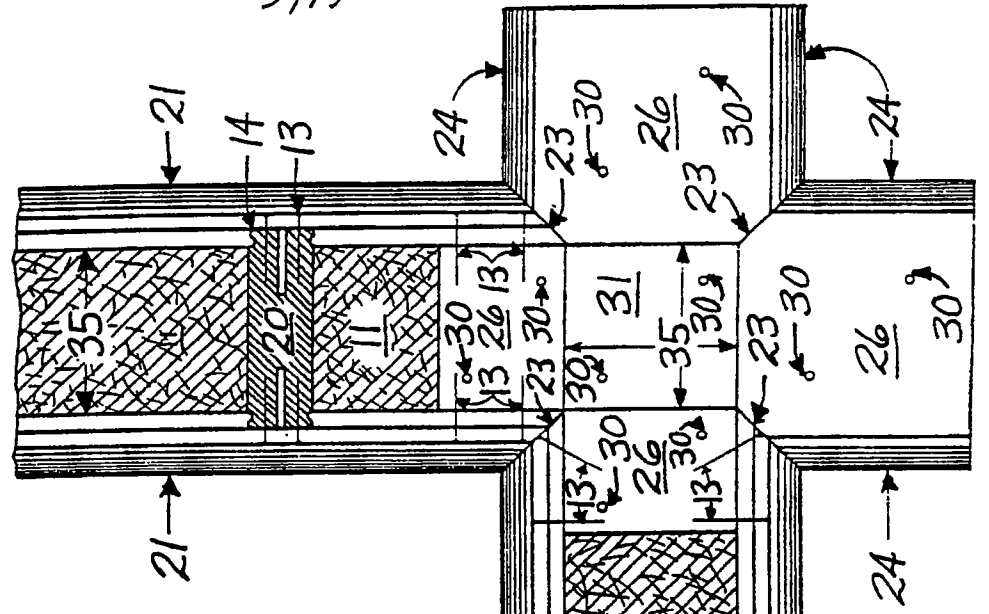

FIG. 26

10/19

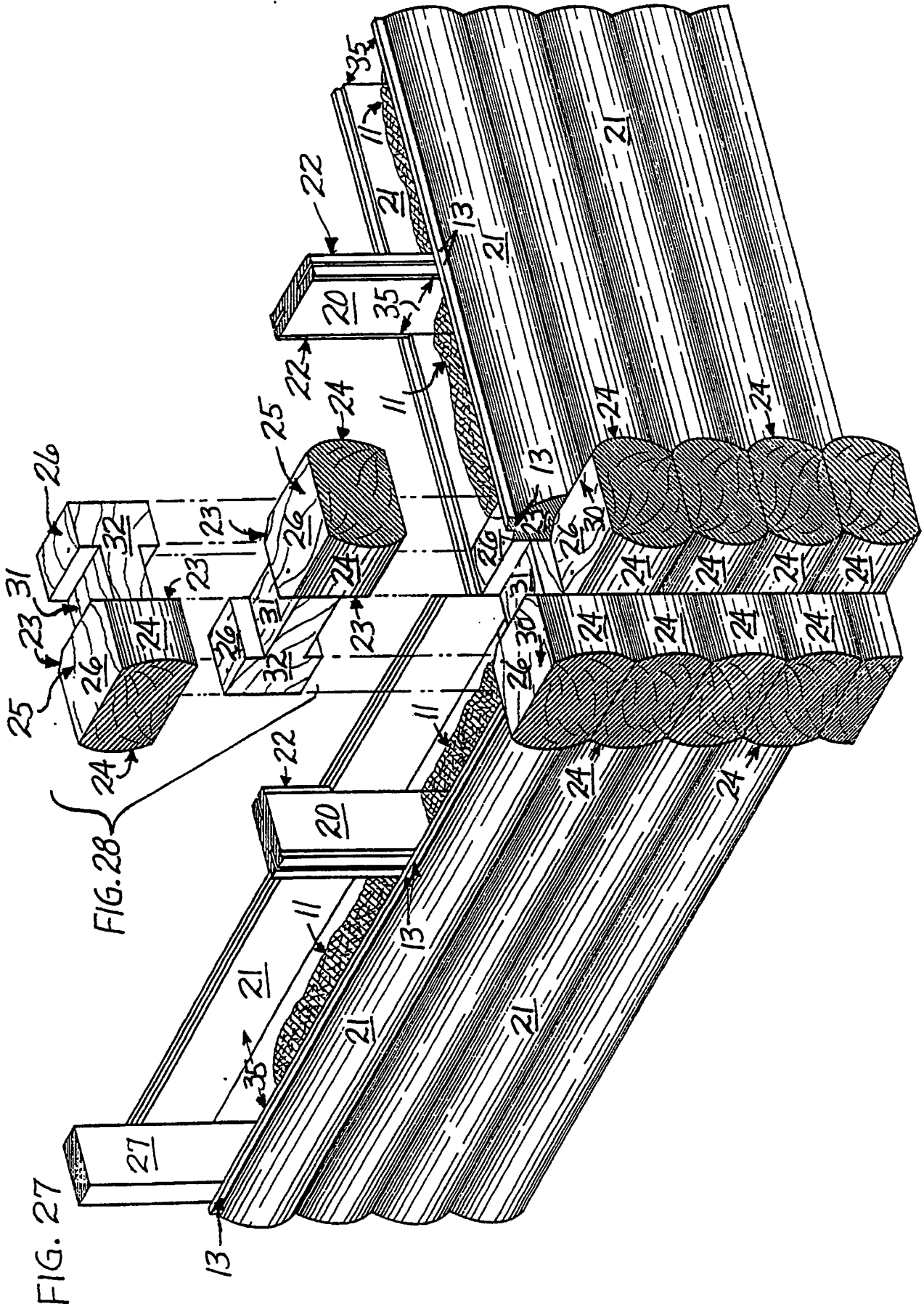

FIG. 29

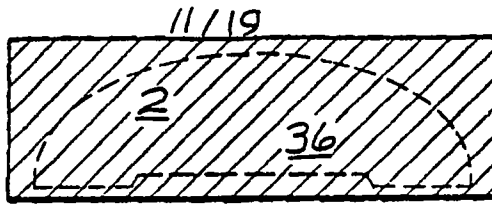

FIG. 30

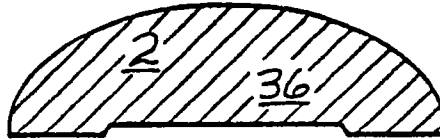

FIG. 31

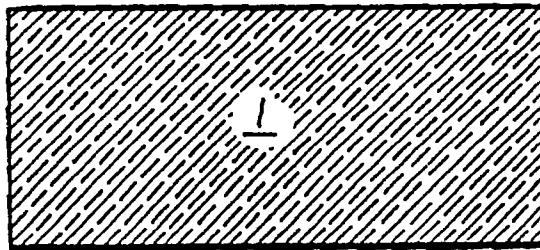

FIG. 32

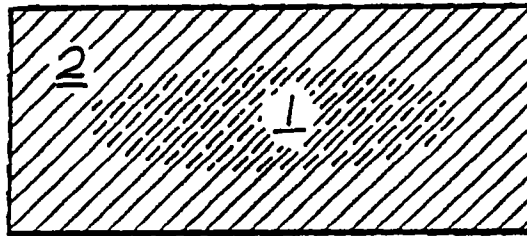

FIG. 33

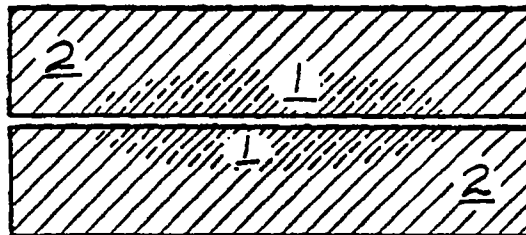
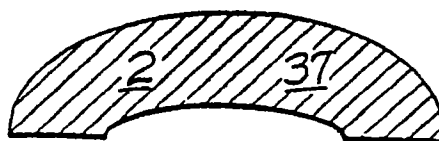

FIG. 34



FIG. 35



12/19

FIG. 36

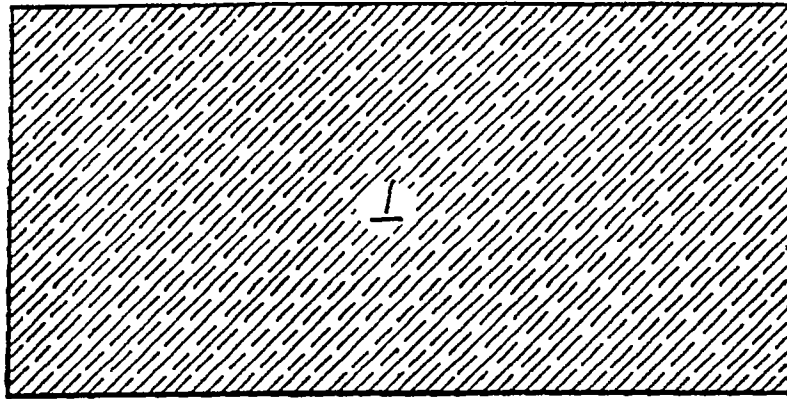

FIG. 37

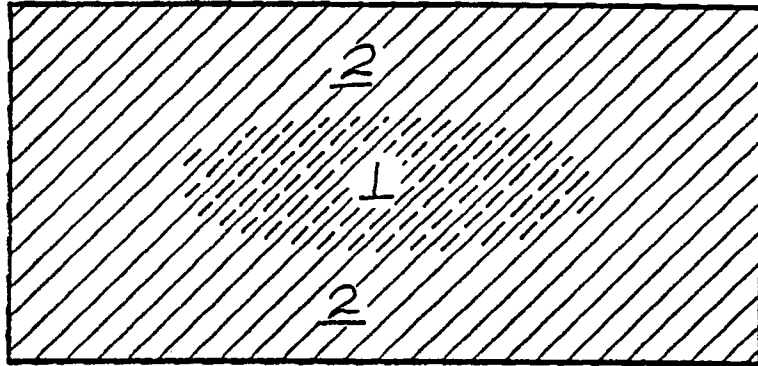

FIG. 38

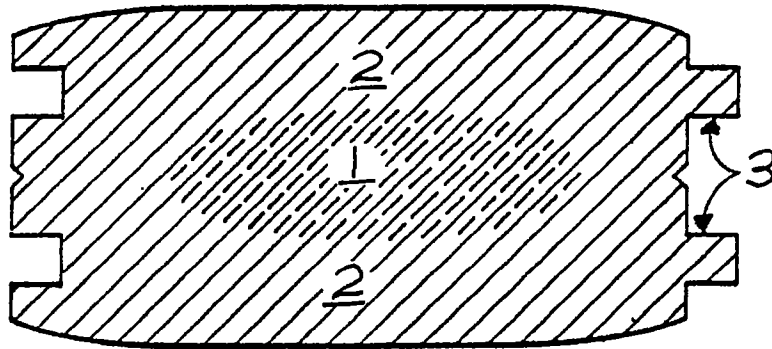

FIG. 39

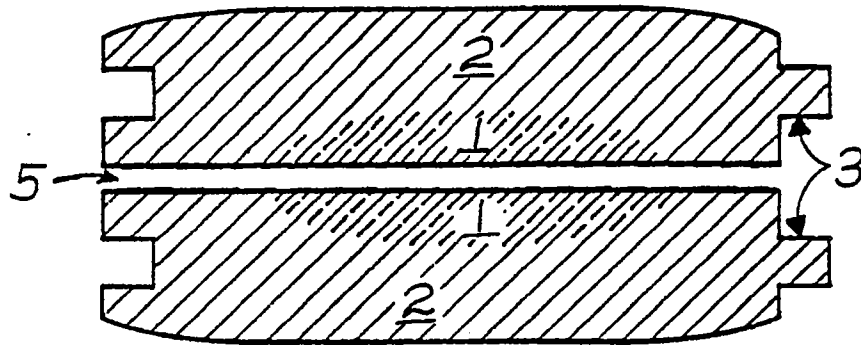

FIG. 40

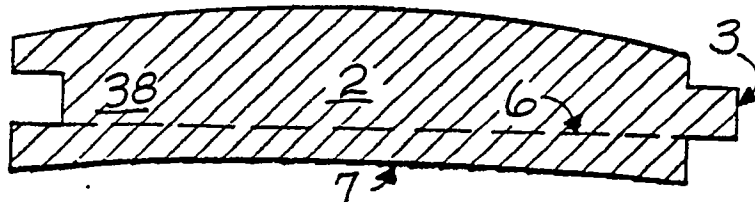
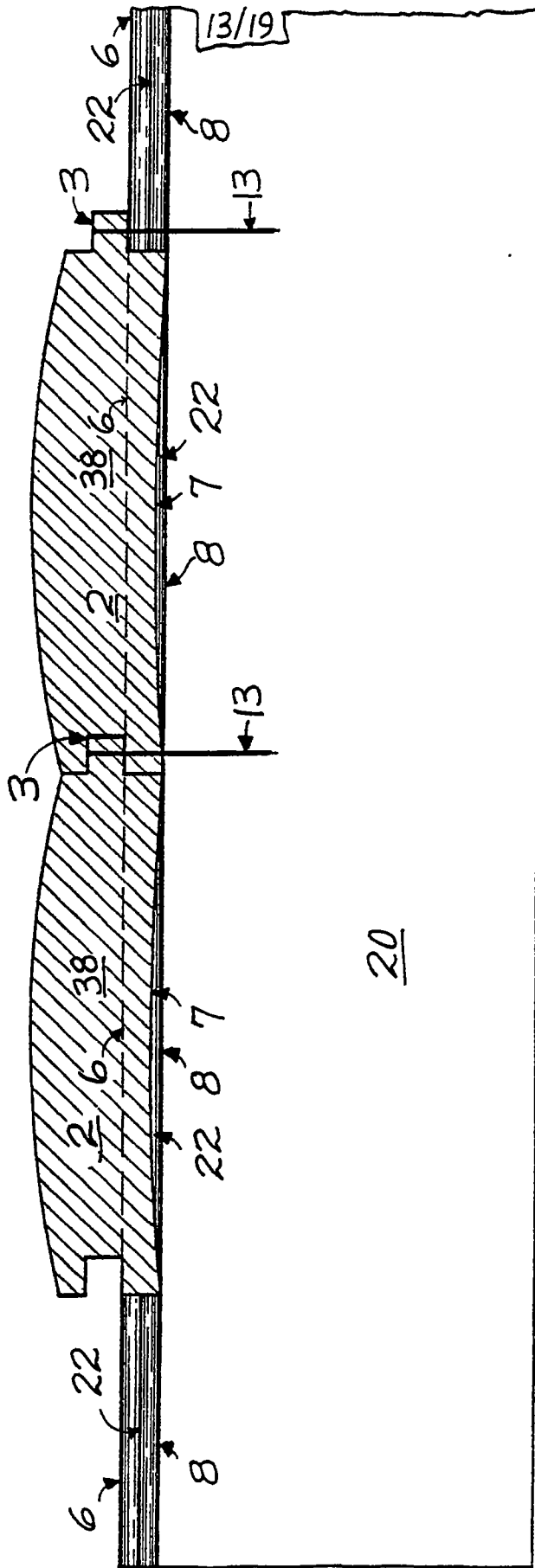

FIG. 41



20

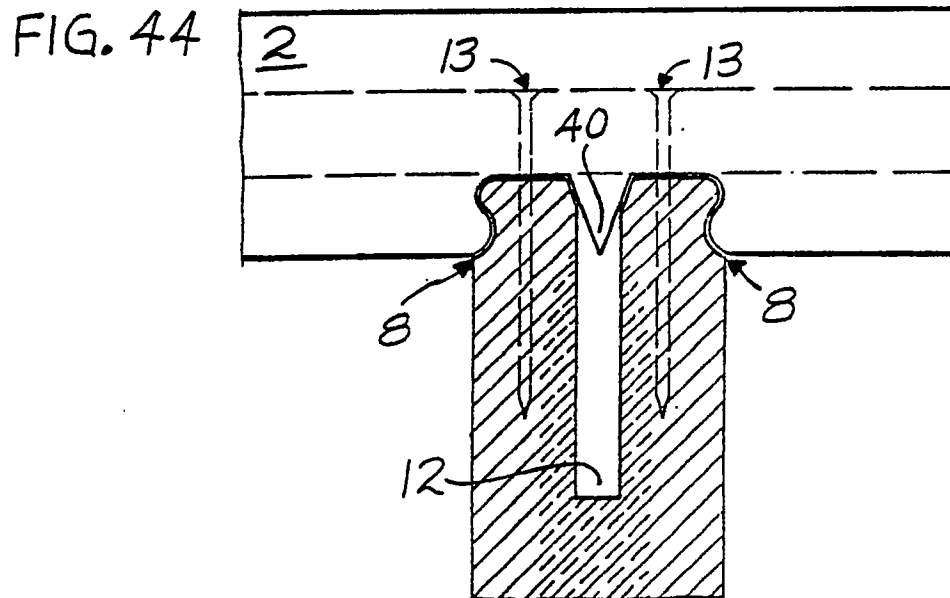
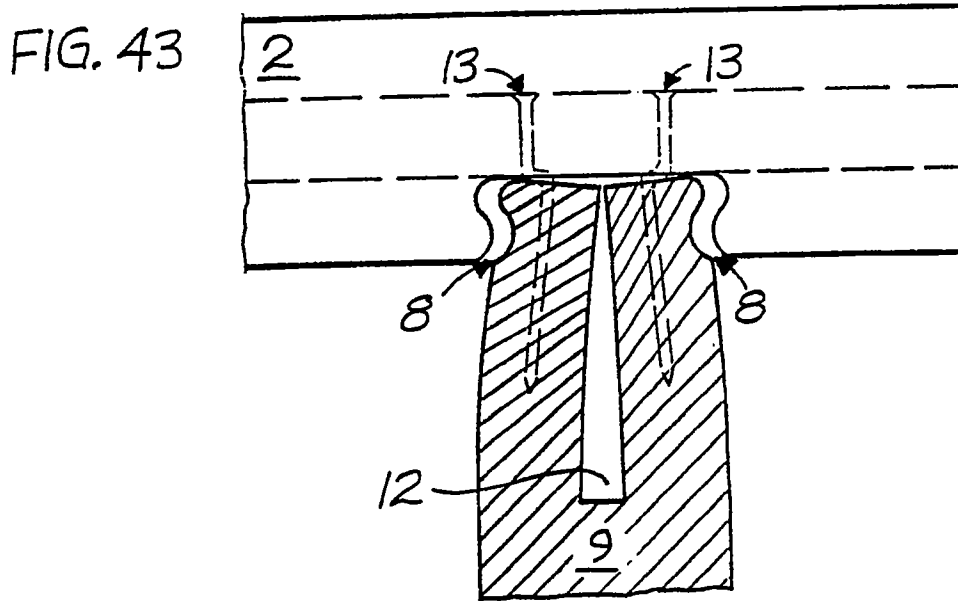
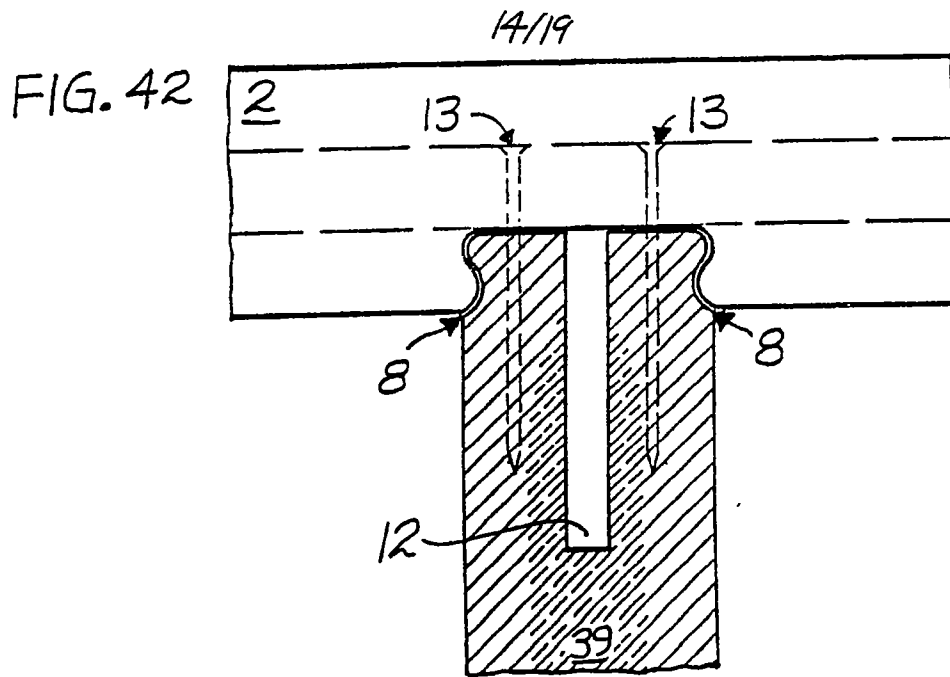

FIG. 45

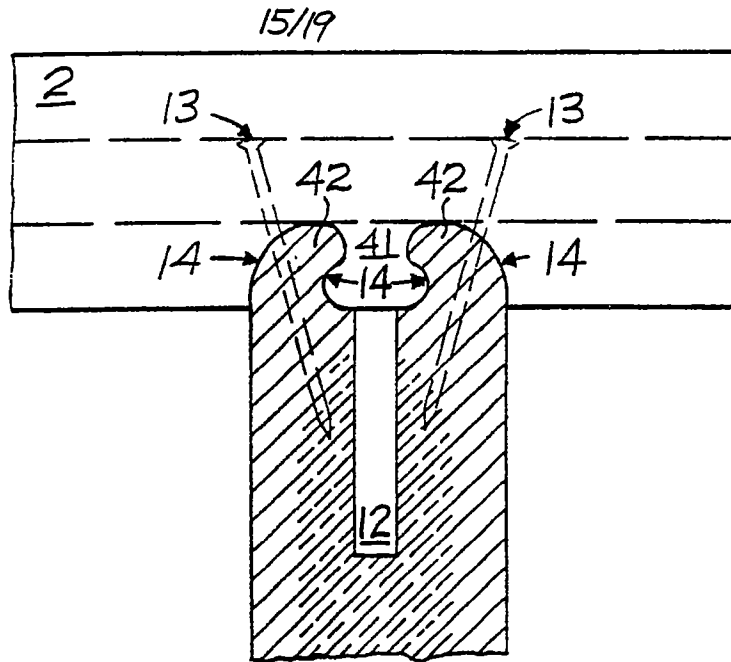

FIG. 46

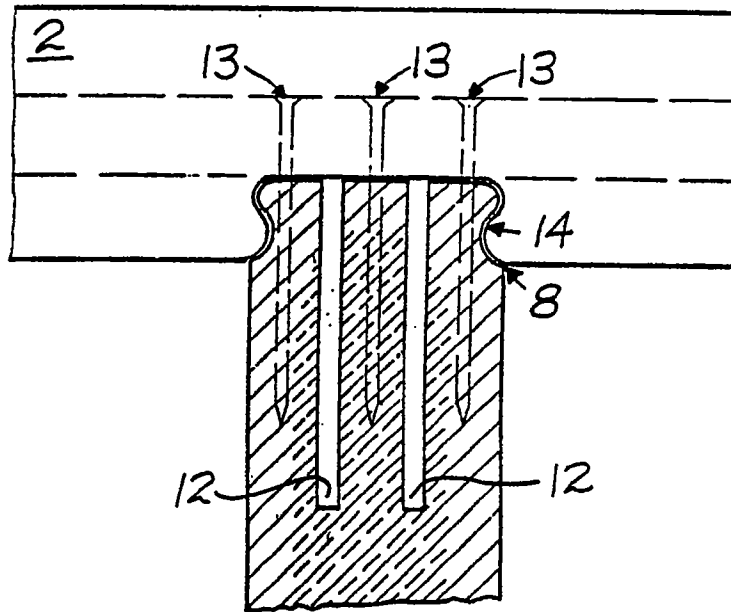
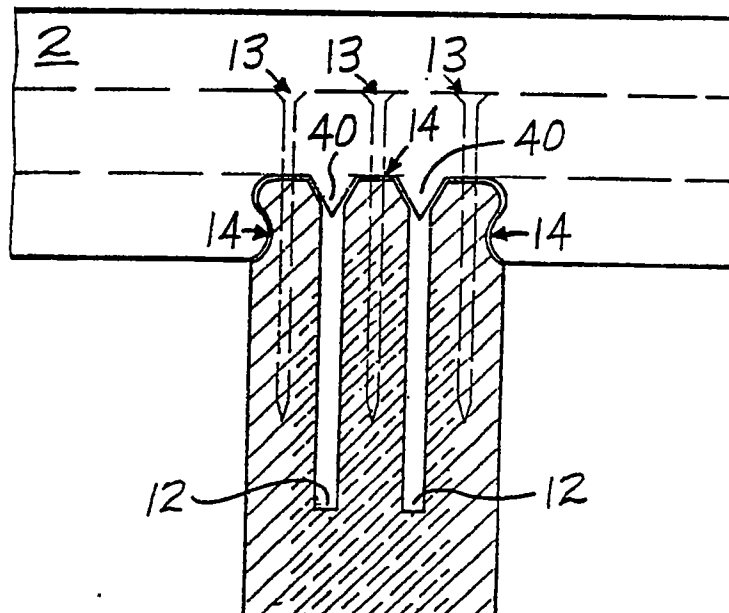

FIG. 47



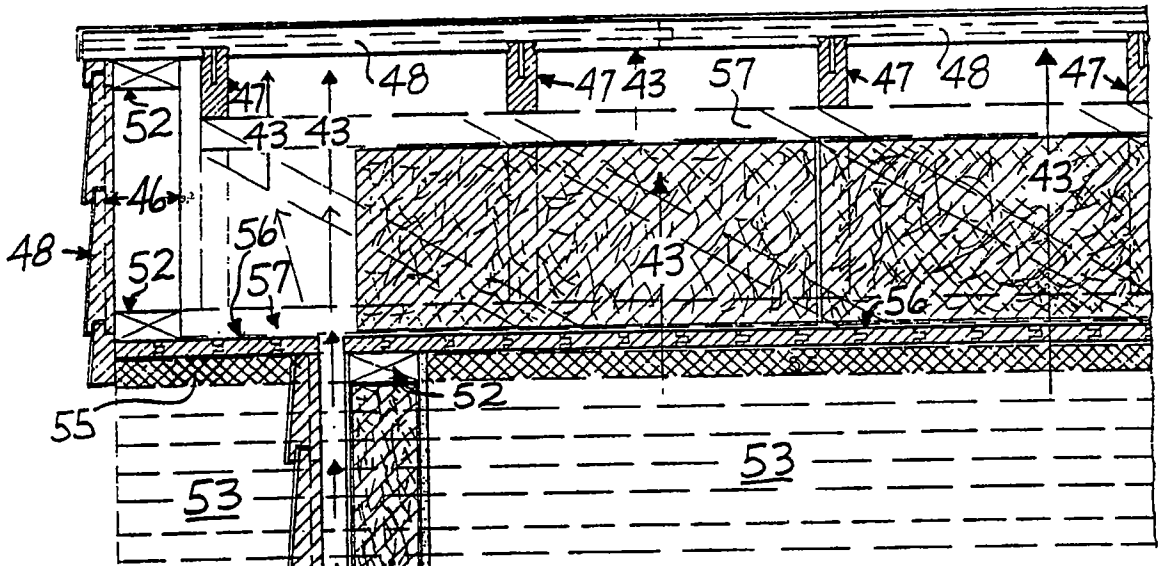
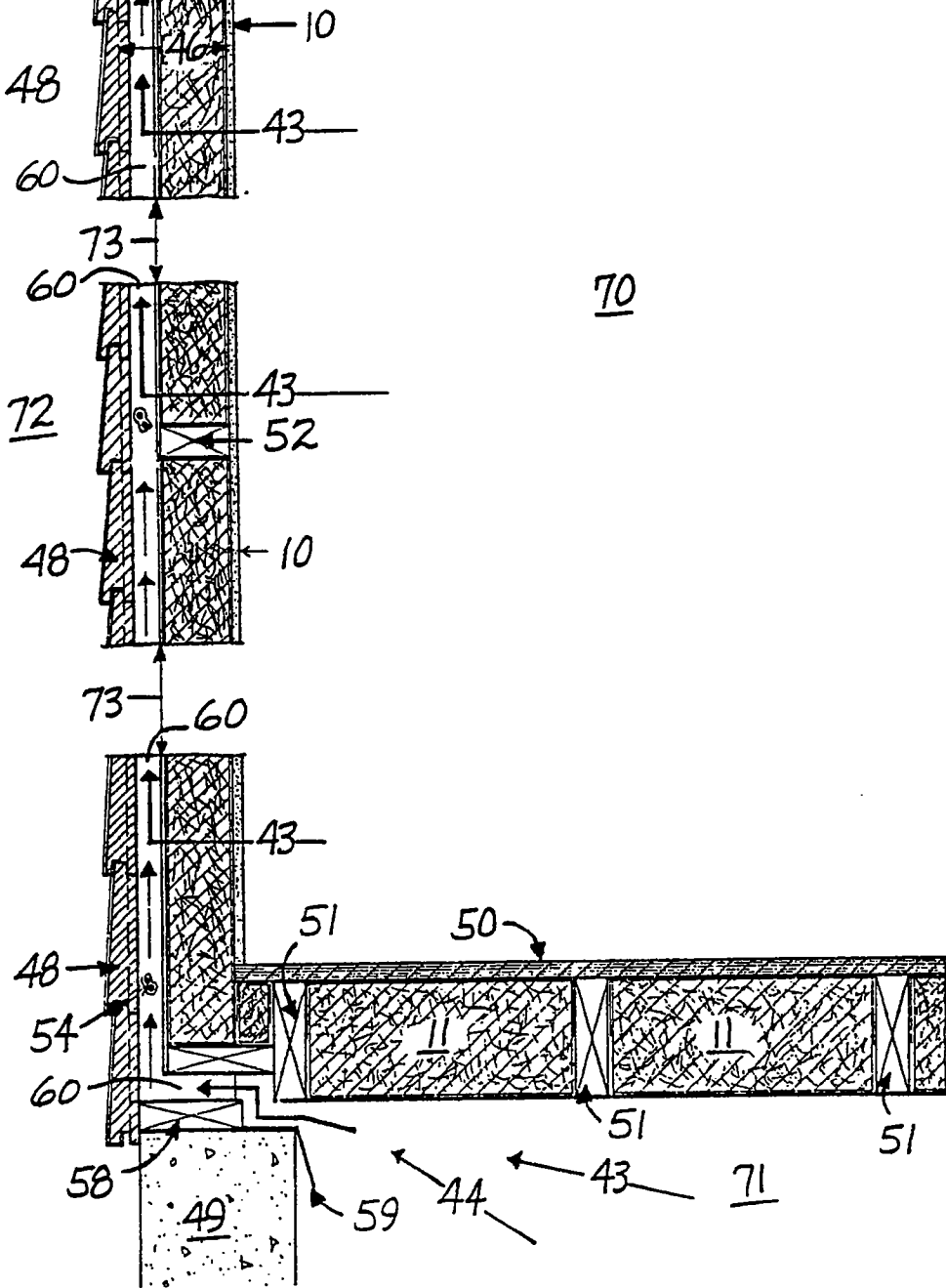

FIG. 48



17/19

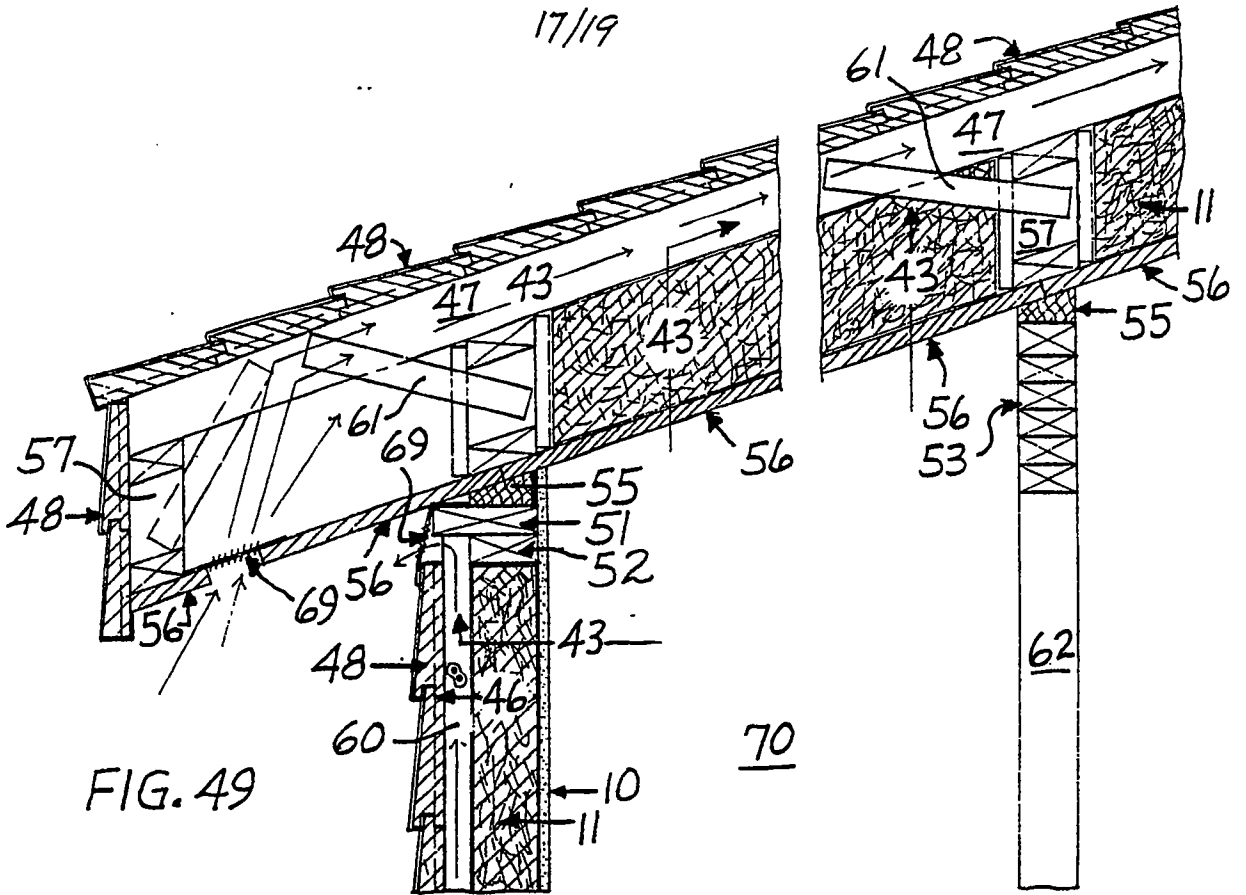
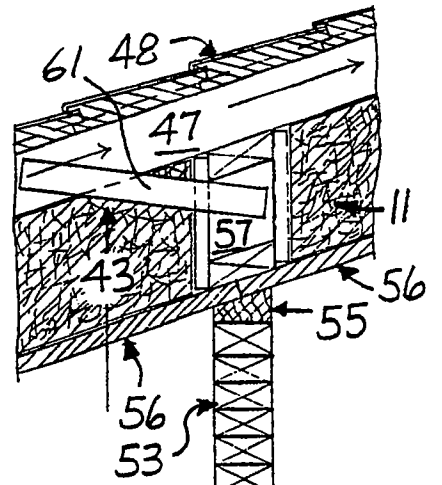
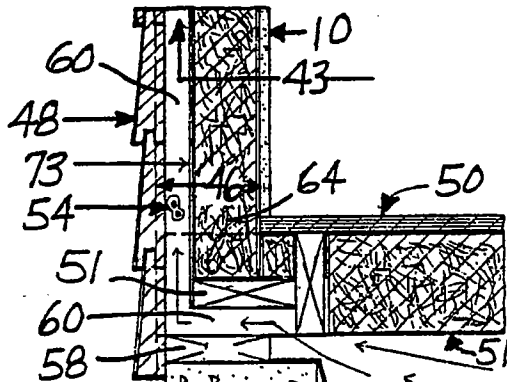
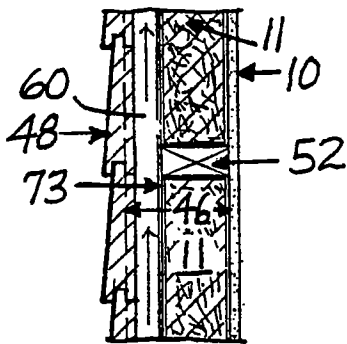

FIG. 49

72



70

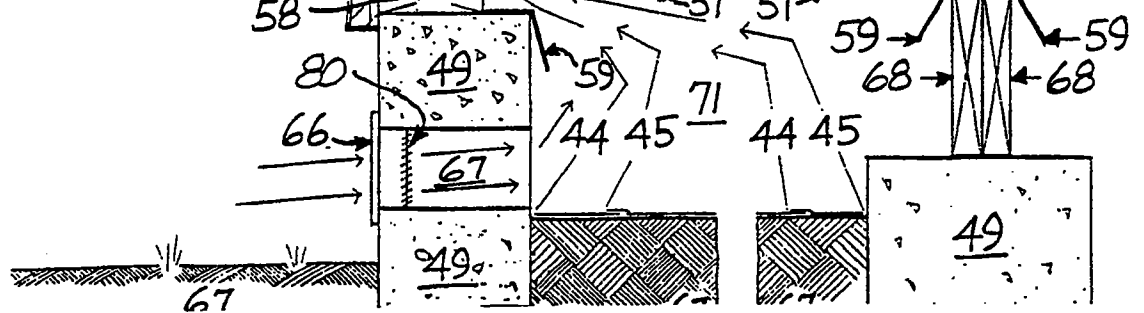
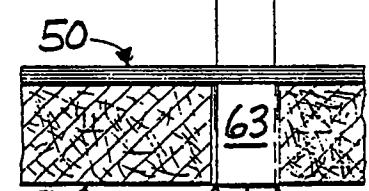

FIG. 50

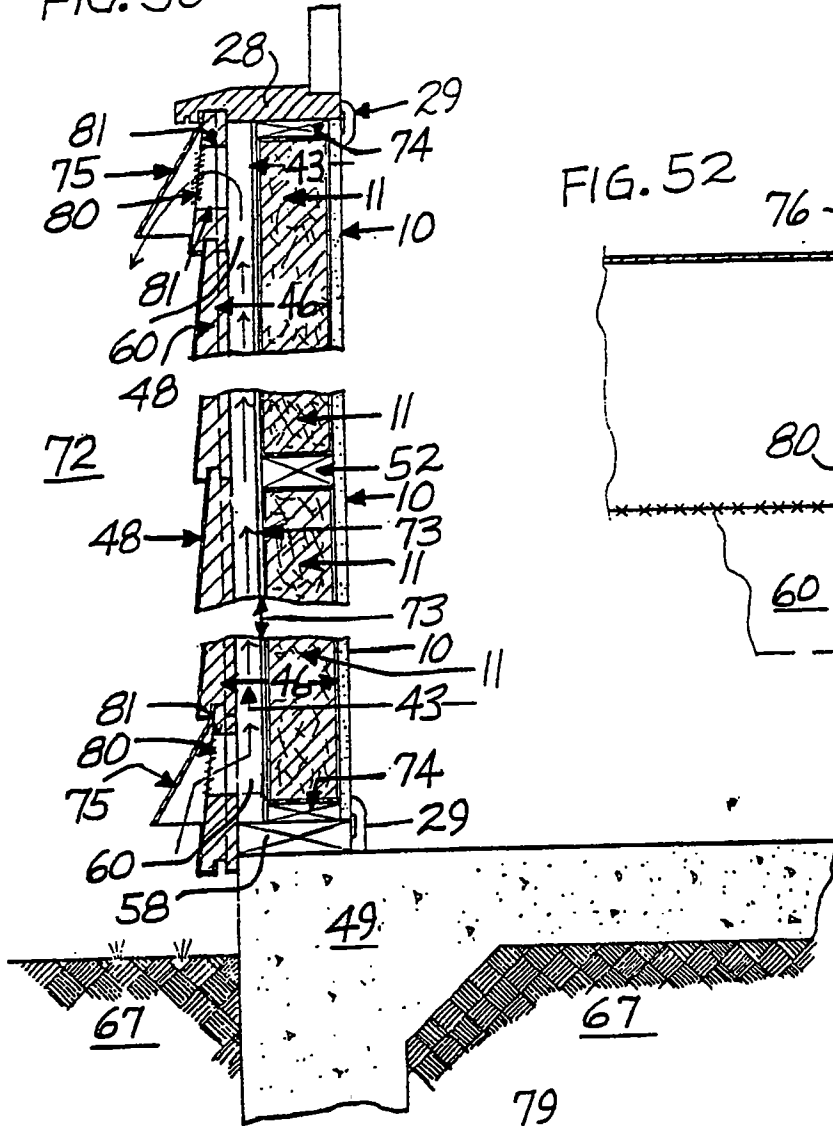

FIG. 52

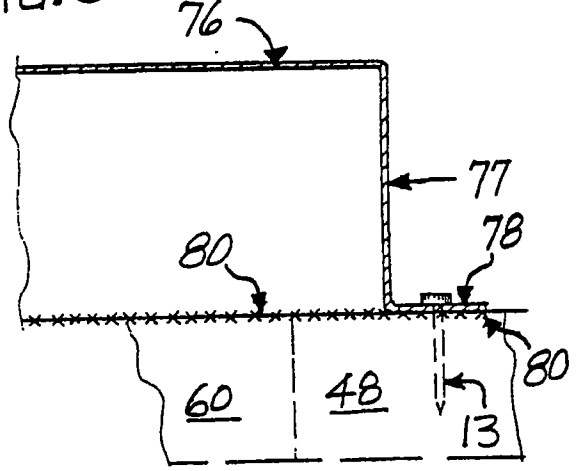
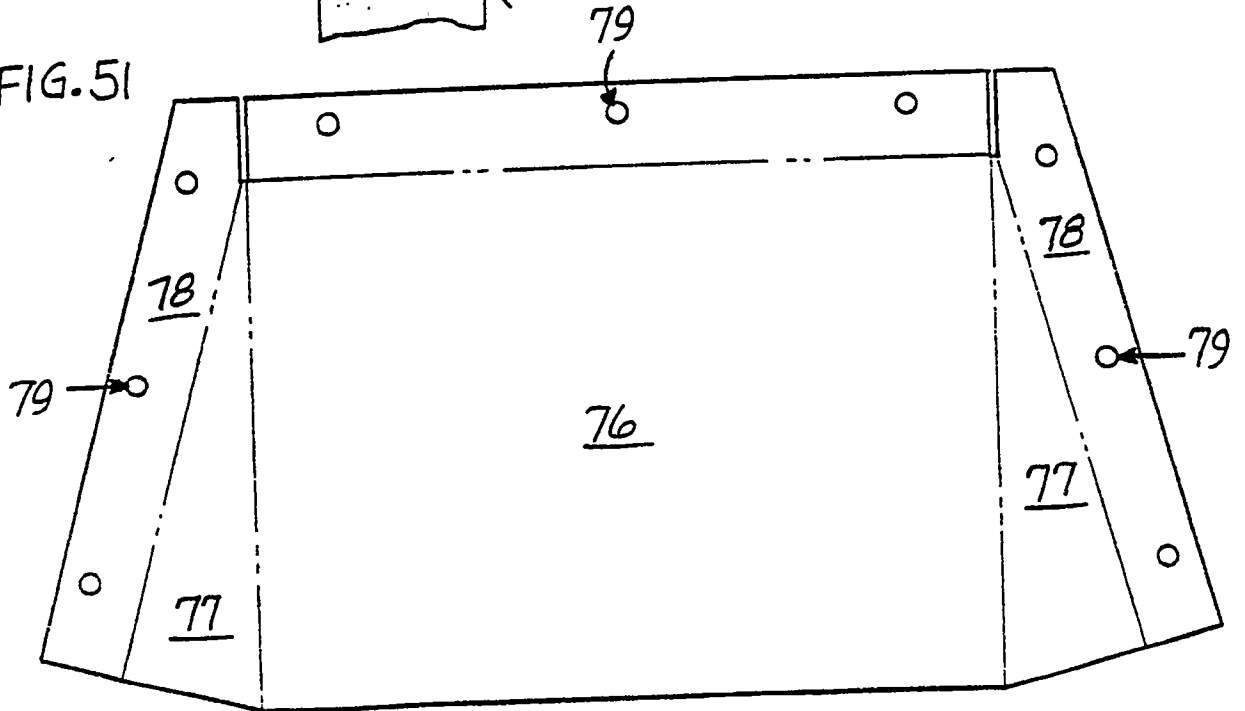
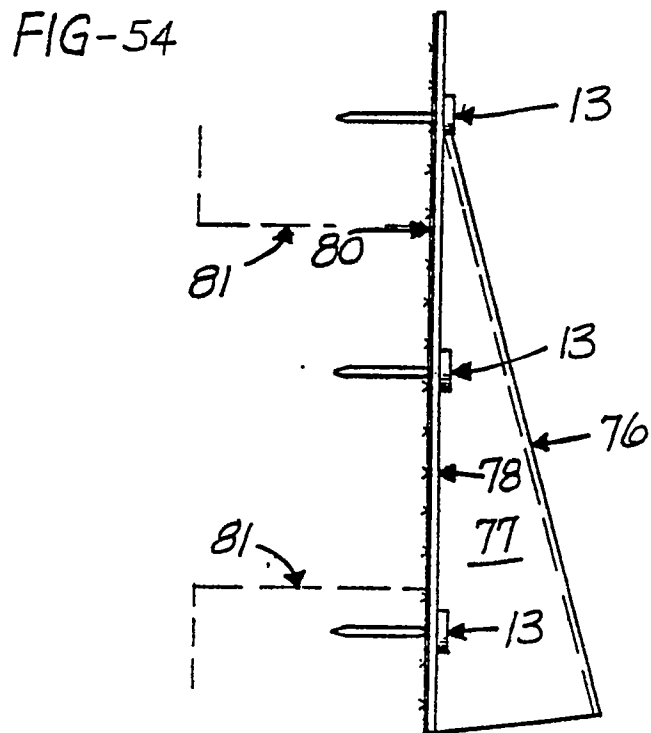
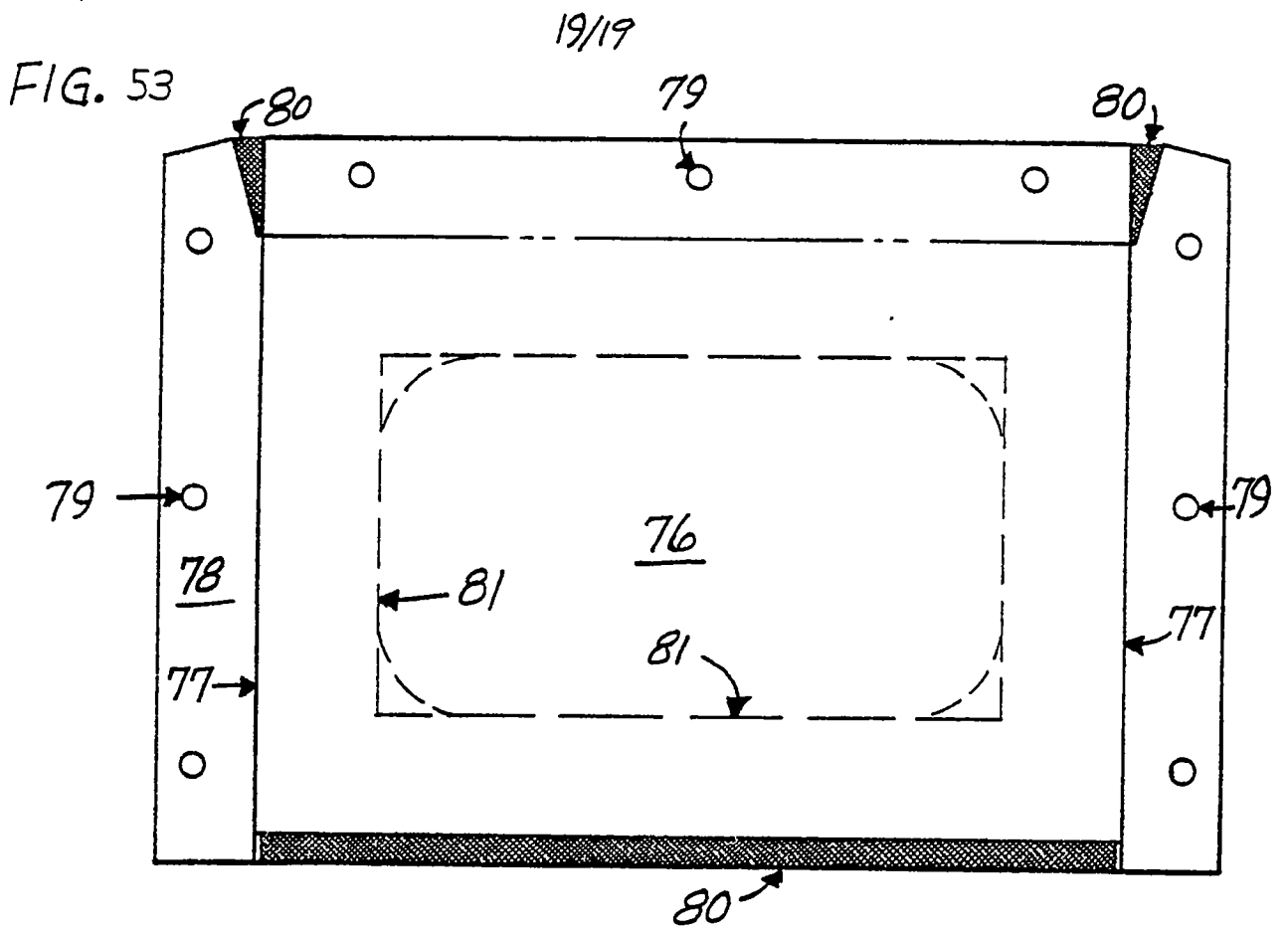

FIG. 51





A. CLASSIFICATION OF SUBJECT MATTER

IPC(5) :E04B 1/10

US CL :52/233,52/95,52/546

According to International Patent Classification (IPC) or to both national classification and IPC

B. FIELDS SEARCHED

Minimum documentation searched (classification system followed by classification symbols)

U.S. : 52/222,533,303,90,725,763,482,478,536, 52/546,459

Documentation searched other than minimum documentation to the extent that such documents are included in the fields searched

Electronic data base consulted during the international search (name of data base and, where practicable, search terms used)

C. DOCUMENTS CONSIDERED TO BE RELEVANT

Category*	Citation of document, with indication, where appropriate, of the relevant passages	Relevant to claim No.
A	US, A, 2,309,453 (HASENBURGER ET AL.) 26 January 1943.	1-7
A	US, A, 1,510,326 (LOCKE) 30 September 1924.	1-7
A	US, A, 2,110,787 (BRANDFORD) 08 March 1938.	1-7
A	US, A, 4,065,902 (LINDAL) 03 January 1978.	11-20
Y	US, A, 4,995,308 (WAGGONER) 26 February 1991, See figures 5-7.	26
Y	US, A, 1,568,997 (BLOUNT) 12 January 1926, See figure 1.	21-23
Y	US, A, 814,154 (McCAHON) 06 March 1906, See figure 1.	24 & 25
A	US, A, 4,098,004 (SLAVIK) 04 July 1978, See figure 2.	21-25
A	US, A, 2,961,804 (BECKMAN) 29 November 1960.	1-7
A	US, A, 3,131,442 (PERSSON-MELIN) 05 May 1964.	1-7
A	US, A, 4,955,169 (SHISKO) 11 September 1990.	1-7

Further documents are listed in the continuation of Box C. See patent family annex.

* Special categories of cited documents:	"T"	later document published after the international filing date or priority date and not in conflict with the application but cited to understand the principle or theory underlying the invention
"A" document defining the general state of the art which is not considered to be part of particular relevance	"X"	document of particular relevance; the claimed invention cannot be considered novel or cannot be considered to involve an inventive step when the document is taken alone
"E" earlier document published on or after the international filing date	"Y"	document of particular relevance; the claimed invention cannot be considered to involve an inventive step when the document is combined with one or more other such documents, such combination being obvious to a person skilled in the art
"L" document which may throw doubts on priority claim(s) or which is cited to establish the publication date of another citation or other special reason (as specified)	"&"	document member of the same patent family
"O" document referring to an oral disclosure, use, exhibition or other means		
"P" document published prior to the international filing date but later than the priority date claimed		

Date of the actual completion of the international search 07 JULY 1992	Date of mailing of the international search report NOV 09 1992
---	---

Name and mailing address of the ISA/ Commissioner of Patents and Trademarks Box PCT Washington, D.C. 20231 Facsimile No. NOT APPLICABLE	Authorized officer ROBERT CANFIELD Telephone No. (703) 308-2168
---	---

C (Continuation). DOCUMENTS CONSIDERED TO BE RELEVANT

Category*	Citation of document, with indication, where appropriate, of the relevant passages	Relevant to claim No.
A	US, A, 1,654,120 (EWING) 27 December 1927.	1-7

BOX II. OBSERVATIONS WHERE UNITY OF INVENTION WAS LACKING

This ISA found multiple inventions as follows:

Group I, claims 1-10 drawn to an interlocking joint and corner system classified in class 52, subclass 233.

Group II claims 11-15 and 17-20 drawn to plank configuration and floor decking classified in class 52, subclass 222.

Group III claim 16 drawn to trim classified in class 52, subclass 459.

Group IV claims 21-25 drawn to a venting system classified in class 52, subclass 303.

Group V claim 26 drawn to a shield classified in class 52, subclass 95.